

Key: 1791

Town of TRURO - Fiscal Year 2024

9/27/2023 7:11 pm SEQ #: 1.812

LEGAL

Table with columns: CURRENT OWNER, PARCEL ID, LOCATION, TRANSFER HISTORY, DOS, T, SALE PRICE, BK-PG (Cert)

Table with columns: CLASS, CLASS%, DESCRIPTION, BN ID, BN, CARD, PMT NO, PMT DT, TY, DESC, AMOUNT, INSP, BY, 1st, %

LAND

Table with columns: CD, T, AC/SF/UN, Nbhd, Infl1, Infl2, ADJ BASE, SAF, Infl3, Lpi, VC, CREDIT AMT, ADJ VALUE

Table with columns: TOTAL, 40,075 SF, ZONING, RES, FRNT, 0, ASSESSED, CURRENT, PREVIOUS, Nbhd, NORTH TRURO, Infl1, NO ADJ, Infl2, NO ADJ

Table with columns: TY, QUAL, COND, DIM/NOTE, YB, UNITS, ADJ PRICE, RCNLD, SHF, A, 1.00, A, 0.75, 12*10, 2006, 120, 16.01, 1,400

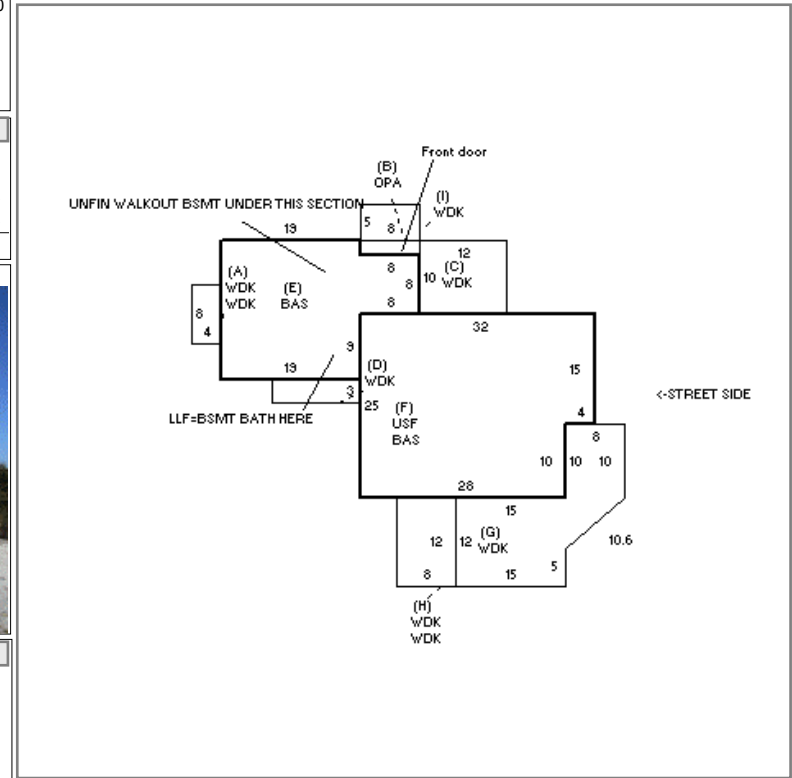
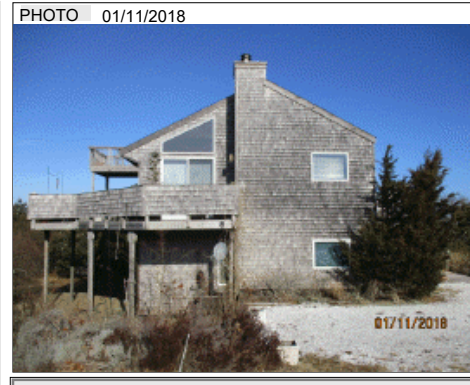

DETACHED

Table with columns: BUILDING, CD, ADJ, DESC, MEASURE, 1/11/2018, LG, MODEL, STYLE, QUALITY, FRAME, LIST, REVIEW

BUILDING

Table with columns: YEAR BLT, SIZE ADJ, ELEMENT, CD, DESCRIPTION, ADJ, S, BAT, T, DESCRIPTION, UNITS, YB, ADJ PRICE, RCN, TOTAL RCN, EFF.YR/AGE, COND, FUNC, ECON, DEPR, RCNLD