

Key: 1802

Town of TRURO - Fiscal Year 2024

9/27/2023 7:11 pm SEQ #: 1.825

LEG  
A  
L  
  
L  
A  
N  
D

CURRENT OWNER				PARCEL ID				LOCATION			
BYRNES ROBERT E JR & PATRICIA PO BOX 373 TRURO, MA 02666-0373				42-220-0				2 ELIZABETH WAY			
TRANSFER HISTORY				DOS	T	SALE PRICE	BK-PG (Cert)				
BYRNES ROBERT E JR & PATR				07/02/1998	QS	59,900	11548-222				

CLASS	CLASS%	DESCRIPTION			BN ID	BN	CARD	
1010	100	SINGLE FAMILY				1	1 of 1	
PMT NO	PMT DT	TY	DESC	AMOUNT	INSP	BY	1st	%
FY2024		35	RES EXEMPT		08/31/2023			0
		30	CHECK DATA		09/14/2005	WL	100	100
02-089	05/02/2002	1	SINGLE FAM R	200,000	03/25/2004	BT	100	100

CD	T	AC/SF/UN	Nbhd	Inf1	Inf2	ADJ BASE	SAF	Inf3	Lpi	VC	CREDIT AMT	ADJ VALUE
100	A	0.775	13	1.00	1	1.00	1	1.00	R05	1.15		320,940
300	A	0.005	13	1.00	1	1.00	1	1.00	R05	1.15		160

TOTAL	33,977 SF	ZONING	RES	FRNT	0	ASSESSED	CURRENT	PREVIOUS
Nbhd	CORN HILL	NOTE				LAND	321,100	279,200
Inf1	NO ADJ		LAND	777,900	639,400			
Inf2	NO ADJ		BUILDING	500	400			
			OTHER	0	0			
			<b>TOTAL</b>	<b>1,099,500</b>	<b>919,000</b>			

TY	QUAL	COND	DIM/NOTE	YB	UNITS	ADJ PRICE	RCNLD
PTD	A	1.00	A 0.75 FRONT 13*16		208	2.30	400
PTD	A	1.00	A 0.75 LEFT 9*9		81	2.30	100



**BLDG COMMENTS**  
 11/18/2021 Owner confirmed int. data at door (C-19).  
 LLF=UNHEATED OPEN RM W/ 2nd KITCHEN  
 (STOVE) and FULL BATH. Timberframe construction.

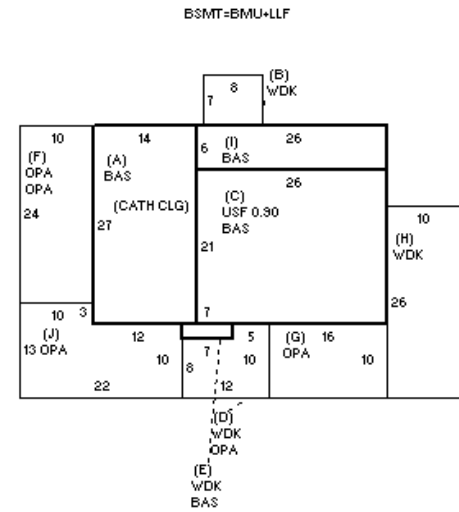

D  
E  
T  
A  
C  
H  
E  
D

BUILDING	CD	ADJ	DESC	MEASURE	11/18/2021	LG
MODEL	1		RESIDENTIAL	LIST	11/18/2021	LG
STYLE	4	1.10	CAPE [100%]	REVIEW	12/3/2010	MR
QUALITY	+	1.15	GOOD-AVE+ [100%]			
FRAME	1	1.00	WOOD FRAME [100%]			

B  
U  
I  
L  
D  
I  
N  
G

YEAR BLT	2002	SIZE ADJ	0.995	ELEMENT	CD	DESCRIPTION	ADJ	S	BAT	T	DESCRIPTION	UNITS	YB	ADJ PRICE	RCN	TOTAL RCN	972,340		
NET AREA	2,460	DETAIL ADJ	1.000	FOUNDATION	4	BSMT WALL	1.00	+	BAS	L	BAS AREA	1,094	2002	389.28	425,874	CONDITION ELEM	CD		
\$NLA(RCN)	\$395	OVERALL	1.120	EXT. COVER	1	WOOD SHINGLES	1.00	+	WDK	N	ATT WOOD DECK	436		61.62	26,865				
CAPACITY			UNITS	ADJ	ROOF SHAPE	1	GABLE	1.00	C	USF	L	UP-STRY FIN	491	2002	306.40	150,444			
STORIES(FAR)	1.9	1.00	ROOF COVER	1	ASPHALT SHINGLE	1.00	+	OPA	N	OPEN PORCH	996		74.97	74,671					
ROOMS	5	1.00	FLOOR COVER	1	HARDWOOD	1.00		LLF	L	LOWER LEVEL FIN	875	2002	256.83	224,731					
BEDROOMS	2	1.00	INT. FINISH	2	DRYWALL	1.00		BMU	N	BSMT UNFINISHED	219		104.69	22,927					
BATHROOMS	3	1.00	HEATING/COOLING	3	RADIANT	1.02		F21	O	FPL 2S 1OP	1		19,282.40	19,282					
FIXTURES	9	\$6,300	FUEL SOURCE	2	GAS	1.00		KIT	O	XTRA KITCHEN	1		21,245.70	21,246					
UNITS	0	1.00						ODS	O	OUT DOOR SHOWER	1		0.00						
																EFF.YR/AGE	2002 / 20		
																COND	20 20 %		
																FUNC	0		
																ECON	0		
																DEPR	20	% GD	80
																RCNLD	\$777,900		