

Key: 1815

Town of TRURO - Fiscal Year 2024

9/27/2023 7:11 pm SEQ #: 1.838

LEGALS

LAND

DETACHED

BUILDING

CURRENT OWNER		PARCEL ID		LOCATION	
JOEL H KIMBALL TRUST & MARY ELLEN KIMBALL TRUST PO BOX 433 TRURO, MA 02666		42-233-0		37 GREAT HOLLOW RD	
TRANSFER HISTORY		DOS	T	SALE PRICE	BK-PG (Cert)
JOEL H KIMBALL TRUST & KIMBALL MARY ELLEN TRUST		11/08/2021	F	100	34643-232
DELBANCO THOMAS L & JILL		03/23/2007	P	650,000	21874-14
		01/15/2003	99		16247-302

CLASS	CLASS%	DESCRIPTION		BN ID	BN	CARD	
1010	100	SINGLE FAMILY			1	1 of 2	
PMT NO	PMT DT	TY	DESC	AMOUNT	INSP	BY	1st %
FY2023		35	RES EXEMPT		01/11/2023		0 0
20-309X	10/21/2020	4	REHAB	26,153	12/29/2020	LG	100 100
07-080	04/30/2007	1	SINGLE FAM R	740,000	04/27/2009	JH	100 100

CD	T	AC/SF/UN	Nbhd	Infl1	Infl2	ADJ BASE	SAF	Infl3	Lpi	VC	CREDIT AMT	ADJ VALUE
100	A	0.775 11	1.00 1	1.00 1	1.00	1,296,360	1.00 1	1.00 V16	3.60			1,004,680
300	A	0.145 11	1.00 1	1.00 1	1.00	99,000	1.00 1	1.00 V16	3.60			14,360

TOTAL	40,075 SF	ZONING	RES	FRNT	0	ASSESSED	CURRENT	PREVIOUS
Nbhd	NORTH TRURO	N	NEW LOC FY08 (CURB CUT BY BOS 10/06.			LAND	1,019,000	886,000
Infl1	NO ADJ	O	RESTRICTIONS PER BK 21874/14=VW EASEMENT			BUILDING	1,480,300	1,270,400
Infl2	NO ADJ	T	F/B/O 42-297+298.			DETACHED	0	0
		E				OTHER	132,600	109,800
						TOTAL	2,631,900	2,266,200

TY	QUAL	COND	DIM/NOTE	YB	UNITS	ADJ PRICE	RCNLD	PHOTO	07/24/2014
									

BUILDING	CD	ADJ	DESC	MEASURE	12/18/2018	LG
MODEL	1		RESIDENTIAL	LIST	12/18/2018	JN
STYLE	1	1.00	RANCH [100%]	REVIEW	4/5/2021	MR
QUALITY	V	1.55	VERY GOOD [100%]			
FRAME	1	1.00	WOOD FRAME [100%]			

YEAR BLT	2007	SIZE ADJ	0.975	ELEMENT	CD	DESCRIPTION	ADJ	S	BAT	T	DESCRIPTION	UNITS	YB	ADJ PRICE	RCN	TOTAL RCN	1,741,531
NET AREA	3,314	DETAIL ADJ	1.000	FOUNDATION	4	BSMT WALL	1.00	A	LLU	N	LOWER LEVEL UNF	1,270		219.95	279,335		
\$NLA(RCN)	\$526	OVERALL	1.000	EXT. COVER	1	WOOD SHINGLES	1.00	+	BAS	L	BAS AREA	2,318	2007	423.05	980,623		
				ROOF SHAPE	1	GABLE	1.00	B	LLF	L	LOWER LEVEL FIN	996	2007	302.87	301,655		
				ROOF COVER	1	ASPHALT SHINGLE	1.00	+	WDK	N	ATT WOOD DECK	1,708		68.12	116,348		
				FLOOR COVER	1	HARDWOOD	1.00	+	OPA	N	OPEN PORCH	404		94.30	38,099		
				INT. FINISH	5	OTHER	1.00	F11	O	FPL 1S 1OP	1		16,371.40	16,371			
				HEATING/COOLING	1	FORCED AIR	1.00	ODS	O	OUT DOOR SHOWER			0.00				
				FUEL SOURCE	2	GAS	1.00										

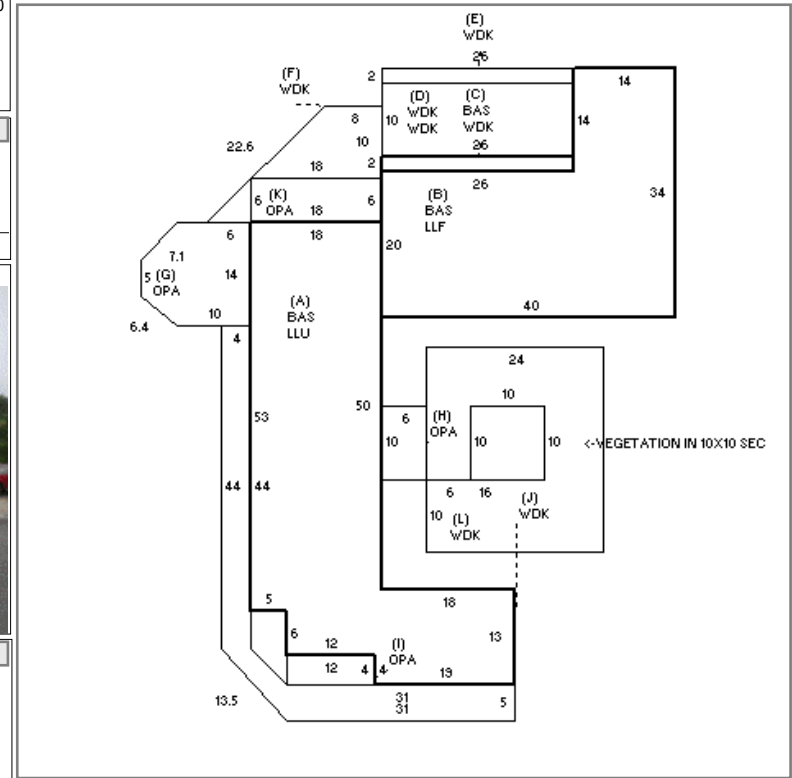

BLDG COMMENTS
INT WALLS=MED DENSITY FIBERBOARD+HEAT=GAS HYDRO AIR (NO A/C).

EFF. YR/AGE	2007 / 15
COND	15 15%
FUNC	0
ECON	0
DEPR	15 % GD 85
RCNLD	\$1,480,300

