

Key: 1934

Town of TRURO - Fiscal Year 2024

9/27/2023 7:11 pm SEQ #: 1.957

LEGAL

Table with columns: CURRENT OWNER, PARCEL ID, LOCATION. Includes owner name PIERSON KATE & COLEMAN MONICA and parcel ID 43-58-0.

Table with columns: CLASS, CLASS%, DESCRIPTION, BN ID, BN, CARD. Includes payment history for 18-456X, 17-019X, 16-239, 03-151A, 03-151B.

LAND

Table with columns: CD, T, AC/SF/UN, Nbh, Infl1, Infl2, ADJ BASE, SAF, Infl3, Lpi, VC, CREDIT AMT, ADJ VALUE. Includes land area details for 100 and 300 acres.

Table with columns: TOTAL, ZONING, RES, FRNT, ASSESSED, CURRENT, PREVIOUS. Includes zoning information (EAST TRURO) and assessed values.

DETAILED

Table with columns: TY, QUAL, COND, DIM/NOTE, YB, UNITS, ADJ PRICE, RCNLD. Includes property details like SHF, ST1, OPA.

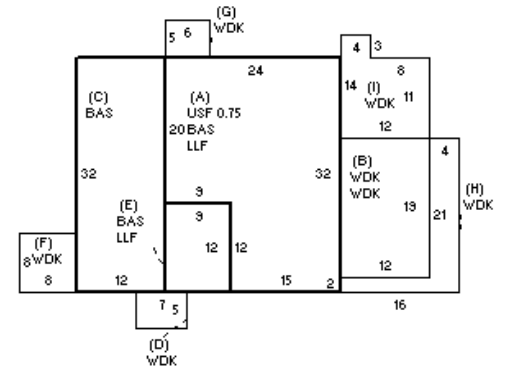

BUILDING

Table with columns: BUILDING, CD, ADJ, DESC, MEASURE. Includes building details like MODEL, STYLE, QUALITY, FRAME.

Table with columns: BLDG COMMENTS. Includes a photo reference: PHOTO 01/04/2017.

INDING

Large summary table with columns: YEAR BLT, NET AREA, \$NLA(RCN), CAPACITY, ELEMENT, CD, DESCRIPTION, ADJ, S, BAT, T, DESCRIPTION, UNITS, YB, ADJ PRICE, RCN, TOTAL RCN, CONDITION ELEM, CD. Includes detailed building specifications and financial summary.

Key: 1934

Town of TRURO - Fiscal Year 2024

9/27/2023 7:11 pm SEQ #: 1.958

LEG
AL

LAN
D

CURRENT OWNER		PARCEL ID	LOCATION			
PIERSON KATE & COLEMAN MONICA care of: ULSTER FINANCIAL SVCS 180 SCHENCK DRIVE KINGSTON, NY 12401		43-58-0	17 WHITMANVILLE RD			
TRANSFER HISTORY		DOS	T	SALE PRICE	BK-PG (Cert)	

CLASS	CLASS%	DESCRIPTION				BN ID	BN	CARD	
1010	100	SINGLE FAMILY					2	2 of 2	
PMT NO	PMT DT	TY	DESC	AMOUNT	INSP	BY	1st	%	

CD	T	AC/SF/UN	Nbhd	Inf1	Inf2	ADJ BASE	SAF	Inf3	Lpi	VC	CREDIT AMT	ADJ VALUE
----	---	----------	------	------	------	----------	-----	------	-----	----	------------	-----------

TOTAL	ZONING	FRNT	ASSESSED	CURRENT	PREVIOUS
Nbhd	NOTE		LAND BUILDING DETACHED OTHER TOTAL	354,600	
Inf1					
Inf2					

PER OWNER 11/3/03 (NO LIST): 1ST FLR=STUDIO (FABRIC WORKSHOP)-HALF BATH+SPACE HEATER;
2ND FLR=GUEST QTRS (2BR+FULL BATH BUT NO KITCH)

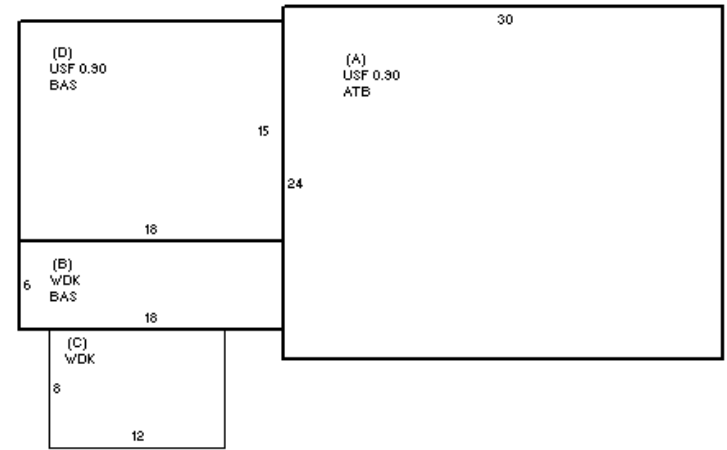

DET
ACH
ED

TY	QUAL	COND	DIM/NOTE	YB	UNITS	ADJ PRICE	RCNLD



BLDG COMMENTS

FY05=2-STORY ADDN TO BARN/WORK
STUDIO=CHGD TO BLDG #2 (WORK STUDIO DOWN,
LIV AREA UP W/HEAT+ BR+BATH (KITCH?)-MAY BE
DET BLDG BUT LEAVE AS COLONIAL TILL LIST

B
U
I
L
D
I
N
G

BUILDING	CD	ADJ	DESC	MEASURE	1/4/2017	LG
MODEL	1		RESIDENTIAL	LIST	1/4/2017	REF
STYLE	5	1.05	COLONIAL [100%]	REVIEW	11/29/2010	MR
QUALITY	+	1.15	GOOD-AVE+ [100%]			
FRAME	1	1.00	WOOD FRAME [100%]			

YEAR BLT	1996	SIZE ADJ	1.030	ELEMENT	CD	DESCRIPTION	ADJ	S	BAT	T	DESCRIPTION	UNITS	YB	ADJ PRICE	RCN	TOTAL RCN	466,597					
NET AREA	1,269	DETAIL ADJ	1.000	FOUNDATION	2	SLAB	0.95	A	ATB	N	ATT BARN	720		103.78	74,719	CONDITION ELEM CD						
\$NLA(RCN)	\$368	OVERALL	0.980	EXT. COVER	1	WOOD SHINGLES	1.00	+	USF	L	UP-STRY FIN	891	1996	271.93	242,285							
				ROOF SHAPE	3	GAMBRELL	1.00	+	BAS	L	BAS AREA	378	1996	352.60	133,284							
				ROOF COVER	1	ASPHALT SHINGLE	1.00	+	WDK	N	ATT WOOD DECK	204		62.79	12,808							
				FLOOR COVER	1	HARDWOOD	1.00															
				INT. FINISH	2	DRYWALL	1.00															
				HEATING/COOLING	7	FL./WALL FURN.	0.98															
				FUEL SOURCE	2	GAS	1.00															
CAPACITY			UNITS	ADJ															EFF.YR/AGE		1998 / 24	
STORIES(FAR)			2	1.00															COND		24 24 %	
ROOMS			0	1.00															FUNC		0	
BEDROOMS			1	1.00															ECON		0	
BATHROOMS			1.5	1.00															DEPR		24 % GD 76	
FIXTURES			5	\$3,500															RCNLD		\$354,600	
UNITS			0	1.00																		