

Key: 1956

Town of TRURO - Fiscal Year 2024

9/27/2023 7:11 pm SEQ #: 1.982

LEGAL

CURRENT OWNER				PARCEL ID				LOCATION			
ABLA JUDITH M REVOCABLE TRUST TRS: ABLA JUDITH M & CHARLES O 36 FRED JACKSON RD SOUTHWICK, MA 01077-9710				43-81-0				4 SYLVAN LN			
TRANSFER HISTORY				DOS	T	SALE PRICE		BK-PG (Cert)			
ABLA JUDITH M REVOCABLE T				12/06/2007	99			22519-223			
ABLA CHARLES O & JUDITH				09/20/1968	99			1413-536			

CLASS	CLASS%	DESCRIPTION			BN ID	BN	CARD
1010	100	SINGLE FAMILY				1	1 of 1
PMT NO	PMT DT	TY	DESC	AMOUNT	INSP	BY	1st %

LAND

CD	T	AC/SF/UN	Nbhd	Inf1	Inf2	ADJ BASE	SAF	Inf3	Lpi	VC	CREDIT AMT	ADJ VALUE
100	A	0.740	12	1.00	1	1.00	1	1.00	R03	1.00		275,110

TOTAL	32,234 SF	ZONING	RES	FRNT	0	ASSESSED	CURRENT	PREVIOUS
Nbhd	EAST TRURO	N O T E	LOT 3			LAND	275,100	239,200
Inf1	NO ADJ		BUILDING	312,800	265,500			
Inf2	NO ADJ		DETACHED	0	0			
			OTHER	0	0			
			TOTAL	587,900	504,700			

DETACHED

TY	QUAL	COND	DIM/NOTE	YB	UNITS	ADJ PRICE	RCNLD



BLDG COMMENTS

FY11 CHGS PER 11/09 MEAS.

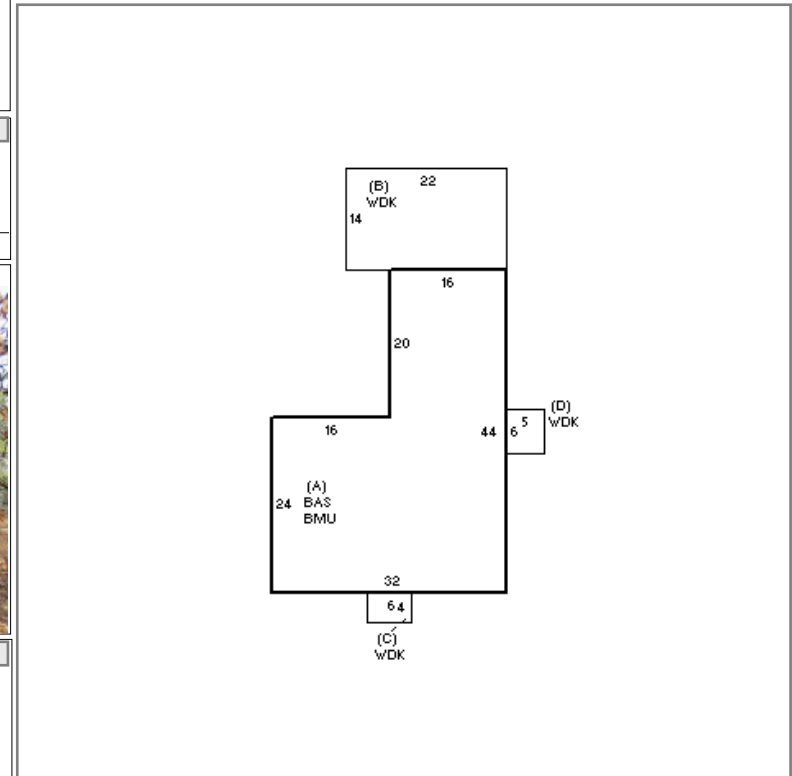

BUILDING

BUILDING	CD	ADJ	DESC	MEASURE	2/23/2018	LG
MODEL	1		RESIDENTIAL	LIST	11/5/2009	EST
STYLE	1	1.00	RANCH [100%]	REVIEW	11/29/2010	MR
QUALITY	A	1.00	AVERAGE [100%]			
FRAME	1	1.00	WOOD FRAME [100%]			

YEAR BLT	1983	SIZE ADJ	1.040	ELEMENT	CD	DESCRIPTION	ADJ
NET AREA	1,088	DETAIL ADJ	1.000	FOUNDATION			1.00
\$NLA(RCN)	\$417	OVERALL	1.020	EXT. COVER	1	WOOD SHINGLES	1.00
CAPACITY				ROOF SHAPE	1	GABLE	1.00
STORIES(FAR)	1	1.00		ROOF COVER	1	ASPHALT SHINGLE	1.00
ROOMS	0	1.00		FLOOR COVER	99	N/A	1.00
BEDROOMS	3	1.00		INT. FINISH	2	DRYWALL	1.00
BATHROOMS	1.5	1.00		HEATING/COOLING	3	RADIANT	1.02
FIXTURES	5	\$3,500		FUEL SOURCE	3	ELECTRIC	1.00
UNITS	0	1.00					

S	BAT	T	DESCRIPTION	UNITS	YB	ADJ PRICE	RCN
A	BMU	N	BSMT UNFINISHED	1,088		73.20	79,636
A	BAS	L	BAS AREA	1,088	1983	322.22	350,581
+	WDK	N	ATT WOOD DECK	362		54.19	19,617

TOTAL RCN	453,334
CONDITION ELEM	CD
EFF.YR/AGE	1983 / 39
COND	31 31 %
FUNC	0
ECON	0
DEPR	31 % GD 69
RCNLD	\$312,800