

Key: 1982

Town of TRURO - Fiscal Year 2024

9/27/2023 7:11 pm SEQ #: 2.011

LEGAL

CURRENT OWNER				PARCEL ID				LOCATION			
HYAMS MARTHA PO BOX 875 TRURO, MA 02666-0875				43-109-0				25 SYLVAN LN			
TRANSFER HISTORY				DOS	T	SALE PRICE	BK-PG (Cert)				
HYAMS MARTHA				11/06/1995	QS	244,500	9916-185				

CLASS	CLASS%	DESCRIPTION			BN ID	BN	CARD	
1040	100	TWO FAMILY				1	1 of 1	
PMT NO	PMT DT	TY	DESC	AMOUNT	INSP	BY	1st	%
FY2018		35	RES EXEMPT		10/01/2017		0	0
90-089	07/18/1990	30	CHECK DATA		05/11/2002	BT	100	100
		1	SINGLE FAM R	60,000	06/22/1993		100	100

LAND

CD	T	AC/SF/UN	Nbhd	Inf1	Inf2	ADJ BASE	SAF	Inf3	Lpi	VC	CREDIT AMT	ADJ VALUE
100	A	0.775	12	1.00	1	378,105	1.00	1.00	V1	1.05		293,030
300	A	0.315	12	1.00	1	28,875	1.00	1.00	V1	1.05		9,100

TOTAL	1.090 Acres	ZONING	RES	FRNT	0	ASSESSED	CURRENT	PREVIOUS
Nbhd	EAST TRURO	N O T E	FY96 CHG FROM 25 SYLVAN LN TO 1 TURNER PATH. FY11=ADDED VIEW (SEE PHOTO).			LAND	302,100	262,700
Inf1	NO ADJ		BUILDING	607,400	515,700			
Inf2	NO ADJ		DETACHED	0	0			
			OTHER	0	0			
			<b>TOTAL</b>	<b>909,500</b>	<b>778,400</b>			

DETACHED

TY	QUAL	COND	DIM/NOTE	YB	UNITS	ADJ PRICE	RCNLD

PHOTO 11/05/2009

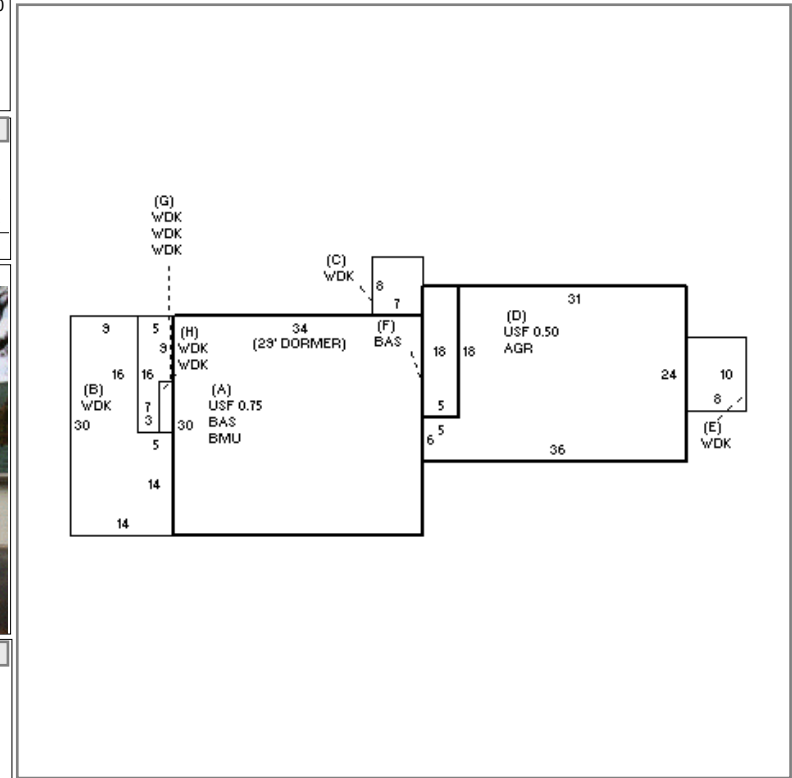
BUILDING

BUILDING	CD	ADJ	DESC	MEASURE	3/20/2018	LG
MODEL	1		RESIDENTIAL	LIST	3/20/2018	LG
STYLE	4	1.10	CAPE [100%]	REVIEW	11/29/2010	MR
QUALITY	A	1.00	AVERAGE [100%]	BLDG COMMENTS		
FRAME	1	1.00	WOOD FRAME [100%]	7/98 ZBA PERMIT FOR 1BR/1BA APT OVER GAR.		

G

YEAR BLT	1991	SIZE ADJ	0.995	ELEMENT	CD	DESCRIPTION	ADJ	S	BAT	T	DESCRIPTION	UNITS	YB	ADJ PRICE	RCN	TOTAL RCN	867,752		
NET AREA	2,262	DETAIL ADJ	1.000	FOUNDATION			1.00	A	BMU	N	BSMT UNFINISHED	1,020		73.05	74,510	CONDITION ELEM	CD		
\$NLA(RCN)	\$384	OVERALL	1.064	EXT. COVER	4	VINYL	1.00	+	USF	L	UP-STRY FIN	1,152	1991	245.44	282,752				
CAPACITY			UNITS	ADJ	ROOF SHAPE	1	GABLE	1.00	+	WDK	N	ATT WOOD DECK	650	47.72	31,018				
STORIES(FAR)	1.75	1.00	ROOF COVER	1	ASPHALT SHINGLE	1.00	1.00	D	AGR	N	ATTACHED GARAGE	774		93.50	72,372				
ROOMS	10	1.00	FLOOR COVER	1	HARDWOOD	1.00	1.00	+	BAS	L	BAS AREA	1,110	1991	321.58	356,954				
BEDROOMS	4	1.00	INT. FINISH	2	DRYWALL	1.00	1.00	WDK	N	ATT WOOD DECK	75			82.72	6,204				
BATHROOMS	4	1.00	HEATING/COOLING	2	HOT WATER	1.02	1.02	WDK	N	ATT WOOD DECK	18			114.51	2,061				
FIXTURES	12	\$8,400	FUEL SOURCE	1	OIL	1.00	1.00	F21	O	FPL 2S 1OP	1			15,928.90	15,929				
UNITS	2	.95						KIT	O	XTRA KITCHEN	1			17,550.80	17,551				
																EFF.YR/AGE	1991 / 31		
																COND	30 30 %		
																FUNC	0		
																ECON	0		
																DEPR	30	% GD	70
																RCNLD	\$607,400		