

Key: 2000

Town of TRURO - Fiscal Year 2024

9/27/2023 7:11 pm SEQ #: 2.034

LEGALS

CURRENT OWNER										PARCEL ID				LOCATION			
RUBIN PHILIP & LAUREN 29 EAST 10TH ST APT 8 NEW YORK, NY 10003										43-128-0				16 HIGGINS HOLLOW RD			
TRANSFER HISTORY										DOS	T	SALE PRICE	BK-PG (Cert)				
RUBIN PHILIP & LAUREN										11/14/2014	O	935,000	28508-194				
COLE PHILIP D & VIRGINIA										10/01/2001	99		14287-133				
COLE PHILIP D & VIRGINIA										03/08/1999	A	350,000	12111-192				
CD	T	AC/SF/UN	Nbhd	Inf1	Inf2	ADJ BASE	SAF	Inf3	Lpi	VC	CREDIT AMT	ADJ VALUE					
100	A	0.775	16	1.00	1	720,200	1.00	1	1.00	SR3	2.00	558,160					
300	A	2.425	16	1.00	1	55,000	1.00	1	1.00	SR3	2.00	133,380					

LAND

TOTAL	3.200 Acres	ZONING	NSD	FRNT	0	ASSESSED	CURRENT	PREVIOUS
Nbhd	NAT'L SEASHORE	NOTE FY03=2001 SURVEY PLAN CHNGS ACREAGE.	LAND		691,500	601,200		
Inf1	NO ADJ		BUILDING		1,061,600	872,200		
Inf2	NO ADJ		DETACHED		3,600	3,500		
		OTHER		209,300	173,200			
TOTAL					1,966,000	1,650,100		

DETACHED

TY	QUAL	COND	DIM/NOTE	YB	UNITS	ADJ PRICE	RCNLD
FBN	A	1.00	A 0.75 15X28		140	21.37	2,200
SHF	A	1.00	A 0.75 10X12	1996	120	16.01	1,400



BUILDING

BUILDING	CD	ADJ	DESC	MEASURE	11/30/2016	LG
MODEL	1		RESIDENTIAL	LIST	6/19/2015	EST
STYLE	7	1.20	OLD STYLE [100%]	REVIEW	5/26/2011	MR
QUALITY	+	1.15	GOOD-AVE+ [100%]			
FRAME	1	1.00	WOOD FRAME [100%]			

BLDG COMMENTS
Garage Apt Address is now # 16A

INDING

YEAR BLT	1849	SIZE ADJ	0.985	ELEMENT	CD	DESCRIPTION	ADJ	S	BAT	T	DESCRIPTION	UNITS	YB	ADJ PRICE	RCN	TOTAL RCN	1,206,385				
NET AREA	2,755	DETAIL ADJ	1.000	FOUNDATION	5	OTHER	1.00	+	CRL	N	CRAWL SPACE	1,810		43.31	78,395	CONDITION ELEM	CD				
\$NLA(RCN)	\$438	OVERALL	1.250	EXT. COVER	2	CLAPBOARD	1.00	+	BAS	L	BAS AREA	942	1849	421.67	397,210						
CAPACITY				ROOF SHAPE	1	GABLE	1.00	+	USF	L	UP-STRY FIN	765	1849	331.69	253,743						
STORIES(FAR)	1.75	1.00	ROOF COVER	2	WOOD SHINGLES	1.01	B	EPA	N	ENCL PORCH	112		196.39	21,995							
ROOMS	7	1.00	FLOOR COVER	1	HARDWOOD	1.00	C	OPA	N	OPEN PORCH	288		99.40	28,627							
BEDROOMS	4	1.00	INT. FINISH	1	PLASTER	1.00	+	BAS	L	BAS AREA	630	2015	421.67	265,650							
BATHROOMS	3.5	1.00	HEATING/COOLING	8	HEAT PUMP	1.04	E	SOL	L	SOLARIUM	238	2015	251.19	59,782							
FIXTURES	15	\$10,500	FUEL SOURCE	2	GAS	1.00	G	USF	L	UP-STRY FIN	180	2015	331.69	59,704							
UNITS	1	1.00					+	WDK	N	ATT WOOD DECK	186		80.85	15,037							
												N	PAT	N	PATIO	847		18.58	15,741		
													ODS	O	OUT DOOR SHOWER			0.00			
																EFF.YR/AGE	2010 / 12				
																COND	12 12 %				
																FUNC	0				
																ECON	0				
																DEPR	12	% GD	88		
																RCNLD	\$1,061,600				

CRAWL SPACE (4' HIGH W/ CONC FLR+WALLS) & DORMERS ADDED 2015

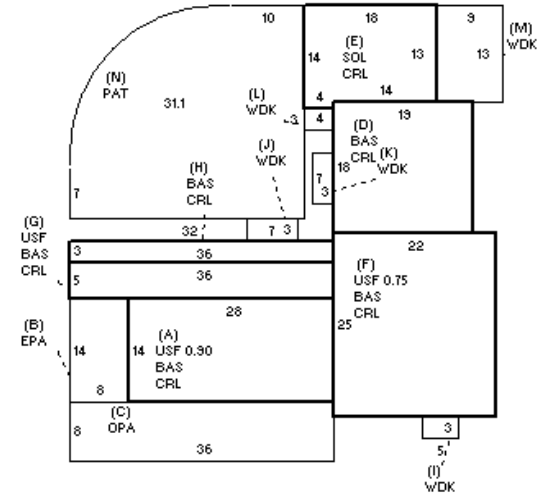

Higgins Hollow Rd

Key: 2000

Town of TRURO - Fiscal Year 2024

9/27/2023 7:11 pm SEQ #: 2.035

LEGAL

CURRENT OWNER				PARCEL ID				LOCATION			
RUBIN PHILIP & LAUREN 29 EAST 10TH ST APT 8 NEW YORK, NY 10003				43-128-0				16 HIGGINS HOLLOW RD			
TRANSFER HISTORY				DOS	T	SALE PRICE	BK-PG (Cert)				

CLASS	CLASS%	DESCRIPTION			BN ID	BN	CARD	
1010	100	SINGLE FAMILY				2	2 of 2	
PMT NO	PMT DT	TY	DESC	AMOUNT	INSP	BY	1st	%

LAND

CD	T	AC/SF/UN	Nbhd	Infl1	Infl2	ADJ BASE	SAF	Infl3	Lpi	VC	CREDIT AMT	ADJ VALUE
----	---	----------	------	-------	-------	----------	-----	-------	-----	----	------------	-----------

DETACHED

TOTAL	ZONING	FRNT	ASSESSED	CURRENT	PREVIOUS
Nbhd	NOTE		LAND	209,300	
Infl1			BUILDING		
Infl2			DETACHED		
			OTHER		
			TOTAL		

TY	QUAL	COND	DIM/NOTE	YB	UNITS	ADJ PRICE	RCNLD	PHOTO
								10/23/2020

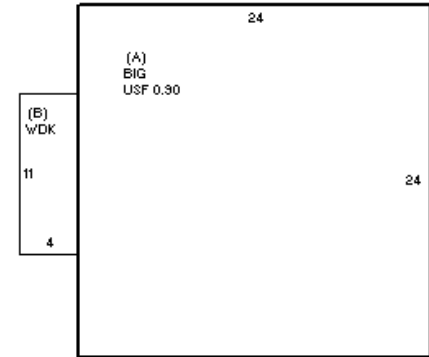

BUILDING

BUILDING	CD	ADJ	DESC	MEASURE	10/23/2020	LG
MODEL	1		RESIDENTIAL	LIST	10/23/2020	LG
STYLE	17	1.00	GAR W/QTRS [100%]	REVIEW		
QUALITY	G	1.35	GOOD [100%]			
FRAME	1	1.00	WOOD FRAME [100%]			

BLDG COMMENTS
Garage Apt Address is 16A

G

YEAR BLT	2020	SIZE ADJ	1.060	ELEMENT	CD	DESCRIPTION	ADJ	S	BAT	T	DESCRIPTION	UNITS	YB	ADJ PRICE	RCN	TOTAL RCN	243,375
NET AREA	518	DETAIL ADJ	1.020	FOUNDATION	2	SLAB	0.95	A	USF	L	UP-STRY FIN	518	2020	338.71	175,451	CONDITION ELEM	
\$NLA(RCN)	\$470	OVERALL	0.990	EXT. COVER	1	WOOD SHINGLES	1.00	A	BIG	N	BUILT-IN GARAGE	576		104.85	60,392	CD	
CAPACITY		UNITS	ADJ	ROOF SHAPE	1	GABLE	1.00	B	W/DK	N	ATT WOOD DECK	44		123.45	5,432		
STORIES(FAR)	0	1.00		ROOF COVER	2	WOOD SHINGLES	1.01										
ROOMS	2	1.00		FLOOR COVER	1	HARDWOOD	1.00										
BEDROOMS	1	1.00		INT. FINISH	2	DRYWALL	1.00										
BATHROOMS	1	1.00		HEATING/COOLING	9	WARM/COOL AIR	1.03										
FIXTURES	3	\$2,100		FUEL SOURCE	2	GAS	1.00										
UNITS	1	1.00															
																EFF.YR/AGE	2008 / 14
																COND	14 14 %
																FUNC	0
																ECON	0
																DEPR	14 % GD 86
																RCNLD	\$209,300