

Key: 2065

Town of TRURO - Fiscal Year 2024

9/27/2023 7:11 pm SEQ #: 2.103

LEGAL

CURRENT OWNER				PARCEL ID				LOCATION			
WEST STREET PROPERTIES INC PO BOX 338 NO TRURO, MA 02652				43-193-0				1 LEeward PASSAGE			
TRANSFER HISTORY				DOS	T	SALE PRICE	BK-PG (Cert)				
WEST STREET PROPERTIES IN GIANGREGORIO ROY J & PATR				04/29/2022	F	750,000	35084-197				
				10/09/2002	QS	177,000	15719-81				
DRYSDALE FAMILY NOM TRUST				12/29/1996	F		10546-250				

CLASS	CLASS%	DESCRIPTION			BN ID	BN	CARD	
1010	100	SINGLE FAMILY				1	1 of 1	
PMT NO	PMT DT	TY	DESC	AMOUNT	INSP	BY	1st	%
08-178	09/18/2008	2	ADDITION	45,000	05/20/2010	JH	100	100
06-067	04/07/2006	6	SHED	1,500	05/11/2007	JH	100	100
02-227	11/05/2002	1	SINGLE FAM R	150,000	03/27/2004	BTT	100	100

LAND

CD	T	AC/SF/UN	Nbhd	Infl1	Infl2	ADJ BASE	SAF	Infl3	Lpi	VC	CREDIT AMT	ADJ VALUE
100	A	0.775 12 1.00	RW6	0.95 1	1.00	342,095	1.00 1	1.00	R03	1.00		265,120
300	A	0.145 12 1.00	1	1.00 1	1.00	31,625	1.00 1	1.00	V4	1.15		4,590

DETACHED

TOTAL	40,075 SF	ZONING	RES	FRNT	0	ASSESSED	CURRENT	PREVIOUS
Nbhd	EAST TRURO	NO VIEW FROM 1ST FL PER 5/07+ 5/10 BP INSPEC (NO ENTRY) BUT AREA IS WOODED.FY14=SHF CHG'D TO UST (IS UNDER OPA ON SFR).				LAND	269,700	283,000
Infl1	RIGHT OF WAY					BUILDING	863,600	741,700
Infl2	NO ADJ					DETACHED	0	0
						OTHER	0	0
						TOTAL	1,133,300	1,024,700

TY	QUAL	COND	DIM/NOTE	YB	UNITS	ADJ PRICE	RCNLD

BUILDING	CD	ADJ	DESC	MEASURE	4/26/2021	LG
MODEL	1		RESIDENTIAL			
STYLE	5	1.05	COLONIAL [100%]	LIST	9/6/2012	EST
QUALITY	A	1.00	AVERAGE [100%]	REVIEW	11/22/2010	MR
FRAME	1	1.00	WOOD FRAME [100%]			

YEAR BLT	2003	SIZE ADJ	0.980	ELEMENT	CD	DESCRIPTION	ADJ	S	BAT	T	DESCRIPTION	UNITS	YB	ADJ PRICE	RCN	TOTAL RCN	1,053,130
NET AREA	3,192	DETAIL ADJ	1.000	FOUNDATION	4	BSMT WALL	1.00	A	BMU	N	BSMT UNFINISHED	504		86.46	43,575		
\$NLA(RCN)	\$330	OVERALL	1.080	EXT. COVER	1	WOOD SHINGLES	1.00	+	BAS	L	BAS AREA	1,008	2003	310.46	312,948		
				ROOF SHAPE	1	GABLE	1.00	+	USF	L	UP-STRY FIN	1,008	2003	245.38	247,343		
				ROOF COVER	1	ASPHALT SHINGLE	1.00	B	LLF	L	LOWER LEVEL FIN	504	2003	220.27	111,016		
				FLOOR COVER	3	W/W CARPET	1.00	+	WDK	N	ATT WOOD DECK	348		54.07	18,816		
				INT. FINISH	2	DRYWALL	1.00	+	OPA	N	OPEN PORCH	144		82.55	11,888		
				HEATING/COOLING	9	WARM/COOL AIR	1.03	G	BGR	N	SF BSMT GARAGE	672		94.00	63,165		
				FUEL SOURCE	1	OIL	1.00	G	BAS	L	BAS AREA	672	2008	310.46	208,632		
								H	UST	N	UTILITY STORAGE	84		114.74	9,638		
									F21	O	FPL 2S 1OP	1		15,924.70	15,925		
									MST	O	MASONRY STACK	1		3,184.70	3,185		
									ODS	O	OUT DOOR SHOWER	1		0.00			

BUILDING



PHOTO 06/30/2021

BLDG COMMENTS

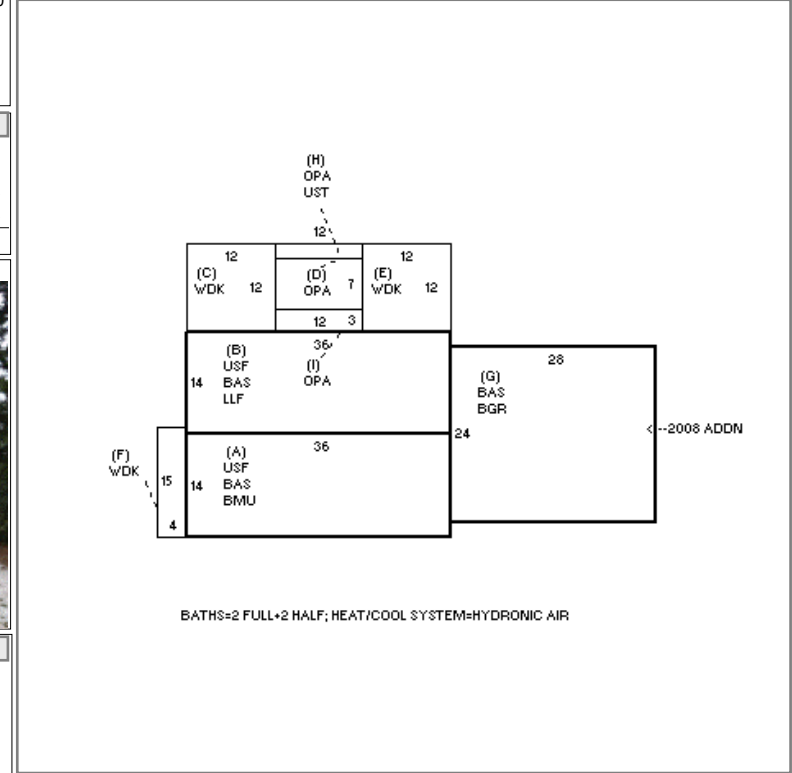

CONDITION ELEM	CD
EFF.YR/AGE	2004 / 18
COND	18 18 %
FUNC	0
ECON	0
DEPR	18 % GD 82
RCNLD	\$863,600