

Key: 2243

Town of TRURO - Fiscal Year 2024

9/27/2023 7:11 pm SEQ #: 2.288

LEGAL

LAND

DETACHED

BUILDING

CURRENT OWNER				PARCEL ID				LOCATION			
PAUL M SOUZA TRUST C/O PINE VALLEY, LLC PO BOX 835 TRURO, MA 02666				46-15-0				250 RT 6			
TRANSFER HISTORY				DOS	T	SALE PRICE	BK-PG (Cert)				
PINE VALLEY, LLC				08/18/2023	F	1	35944-57				
PAUL M SOUZA TRUST				02/21/2019	F	1	31845-137				
SOUZA PAUL M				11/22/1977	99	30,000	2620-104				

CLASS	CLASS%	DESCRIPTION			BN ID	BN	CARD	
3250	100	SMALL RETAIL				1	1 of 1	
PMT NO	PMT DT	TY	DESC	AMOUNT	INSP	BY	1st	%
20-182	07/20/2020	80	SOLAR TAXABL	30,000	10/05/2020	LG	100	100
13-201	08/19/2013	90	BP NVC	14,800	06/12/2014	RJM	100	100
92-131	11/13/1992	11	COMMERCIAL	2,500	12/31/1992		100	100
89-163	10/27/1989	11	COMMERCIAL	3,000	09/05/1990		100	100

CD	T	AC/SF/UN	Nbhd	Inf1	Inf2	ADJ BASE	SAF	Inf3	Lpi	VC	CREDIT AMT	ADJ VALUE
103	S	33,750	RT6	1.00	1	1.00	1	1.00	1.00	C02	1.00	299,360
203	A	0.775	RT6	1.00	1	1.00	1	1.00	1.00	C02	1.00	59,520
303	A	1.550	RT6	1.00	1	1.00	1	1.00	1.00	C02	1.00	40,610

TOTAL	3.100 Acres	ZONING	RES	FRNT	0	ASSESSED	CURRENT	PREVIOUS
Nbhd	ROUTE 6	NOTE				LAND	399,500	388,000
Inf1	NO ADJ		BUILDING	318,700	313,200			
Inf2	NO ADJ		DETACHED	10,900	10,300			
			OTHER	0	0			
						TOTAL	729,100	711,500

TY	QUAL	COND	DIM/NOTE	YB	UNITS	ADJ PRICE	RCNLD
C06	A	1.00	A 0.75	1987	300	8.70	2,000
GHD	M	0.60	D 0.20	1987	2,400	16.05	7,700
SHF	A	1.00	A 0.75	1987	96	16.47	1,200

PHOTO 10/05/2020

BLDG COMMENTS
BAYBERRY GARDENS

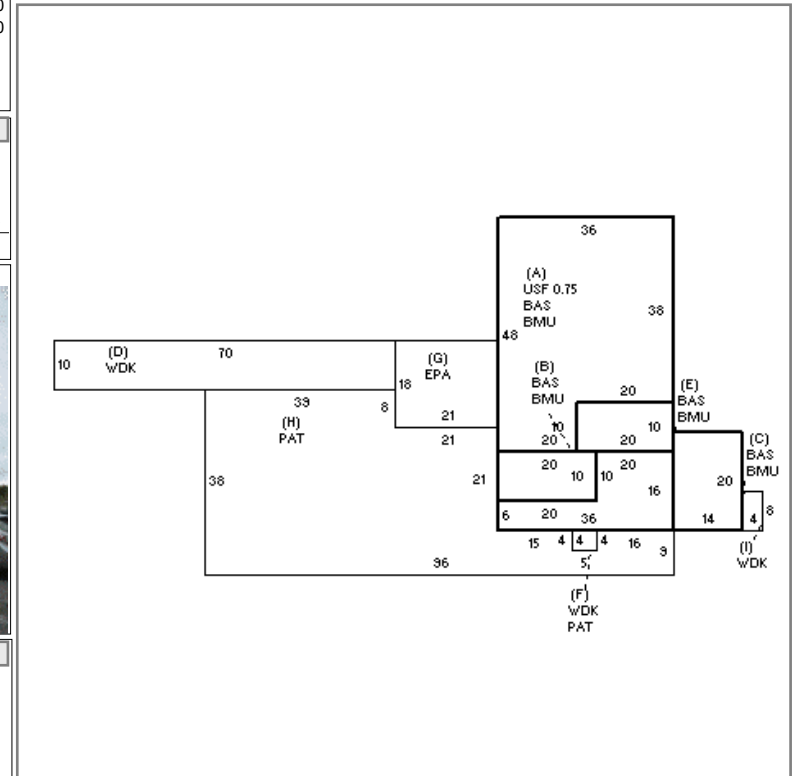

BUILDING	CD	ADJ	DESC	MEASURE	10/31/2011	DF
MODEL	5		CIM	LIST	10/31/2011	DF
STYLE	31	1.95	STORE(SM. RET) [100%]	REVIEW	6/13/2014	RJM
QUALITY	L	0.83	LOW COST [100%]			
FRAME	1	1.00	WOOD FRAME [100%]			

YEAR BLT	1987	SIZE ADJ	0.865	ELEMENT	CD	DESCRIPTION	ADJ	S	BAT	T	DESCRIPTION	UNITS	YB	ADJ PRICE	RCN	TOTAL RCN	692,867		
NET AREA	4,012	DETAIL ADJ	1.701	FOUNDATION	4	BSMT WALL	1.00	+	BMU	N	BSMT UNF	2,584		44.21	114,249	CONDITION ELEM	CD		
\$NLA(RCN)	\$173	OVERALL	1.000	EXTERIOR WALL	1	WOOD SHINGLES	1.00	+	BAS	L	BASE AREA	2,184	1987	124.95	272,885				
				ROOF STRUCTURE	1	GABLE	1.00	A	USF	L	UP-STRY FIN	1,428	1987	124.95	178,425				
				ROOF COVER	1	ASPH/COMP SHIN	1.00	+	BAS	L	BASE AREA	400	1987	124.95	49,979				
				FLOORING	2	SOFTWOOD	0.95	+	WDK	N	WOOD DECK	752		32.86	24,707				
				INT FINISH	6	MINIMUM	0.95	+	PAT	N	PATIO	2,436		10.38	25,290				
				H.V.A.C.	1	FORCED AIR	1.00	G	EPA	N	ENCL PORCH	378		72.31	27,332				
				FUEL SOURCE	2	GAS	1.00												
				COMPLEX	0		1.00												
				EFF.YR/AGE 1988 / 34															
				COND 54 54 %															
				FUNC 0															
				ECON 0															
				DEPR 54 % GD 46															
				RCNLD \$318,700															