

Key: 2245

Town of TRURO - Fiscal Year 2024

9/27/2023 7:11 pm SEQ #: 2.290

LEGAL

LAND

DETACHED

BUILDING

CURRENT OWNER				PARCEL ID				LOCATION				
COBBLE HILL REALTY TRUST				46-17-0				2 JEANS WAY				
TRS: HYDE BRIAN R				TRANSFER HISTORY				DOS	T	SALE PRICE	BK-PG (Cert)	
PO BOX 263				COBBLE HILL REALTY TRUST				01/13/1992	QS	75,000	7834-121	
TRURO, MA 02666-0263												

CLASS	CLASS%	DESCRIPTION			BN ID	BN	CARD	
1010	100	SINGLE FAMILY				1	1 of 1	
PMT NO	PMT DT	TY	DESC	AMOUNT	INSP	BY	1st	%
02-215	10/18/2002	10	ALL OTHERS	13,000	03/27/2003	BT	100	100
95-103	08/05/1995	10	ALL OTHERS	8,000	06/19/1996		100	100
94-121	05/16/1994	9	DECK	3,800	06/26/1995		100	100
92-011	01/17/1992	1	SINGLE FAM R	90,000	06/07/1993		100	100

CD	T	AC/SF/UN	Nbhd	Inf1	Inf2	ADJ BASE	SAF	Inf3	Lpi	VC	CREDIT AMT	ADJ VALUE
100	A	0.775	13	1.00	1	1.00	1	1.00	R06	1.25		348,850
300	A	0.325	13	1.00	1	1.00	1	1.00	R06	1.25		11,170

TOTAL	1.100 Acres				ZONING	RES	FRNT	0	ASSESSED	CURRENT	PREVIOUS
Nbhd	CORN HILL				NO VW FROM 2ND FLR PER FY11 FIELD REV (FROM ROOF DK ONLY).	LAND			360,000	288,000	
Inf1	NO ADJ					BUILDING			727,300	598,600	
Inf2	NO ADJ					DETACHED			1,700	1,600	
					OTHER			0	0		
					TOTAL			1,089,000	888,200		

TY	QUAL	COND	DIM/NOTE	YB	UNITS	ADJ PRICE	RCNLD
FBN	A	1.00	D 0.20 20*20	1995	400	21.37	1,700



BLDG COMMENTS  
3/4 UPPER STORY OVER GAR=UNFIN?

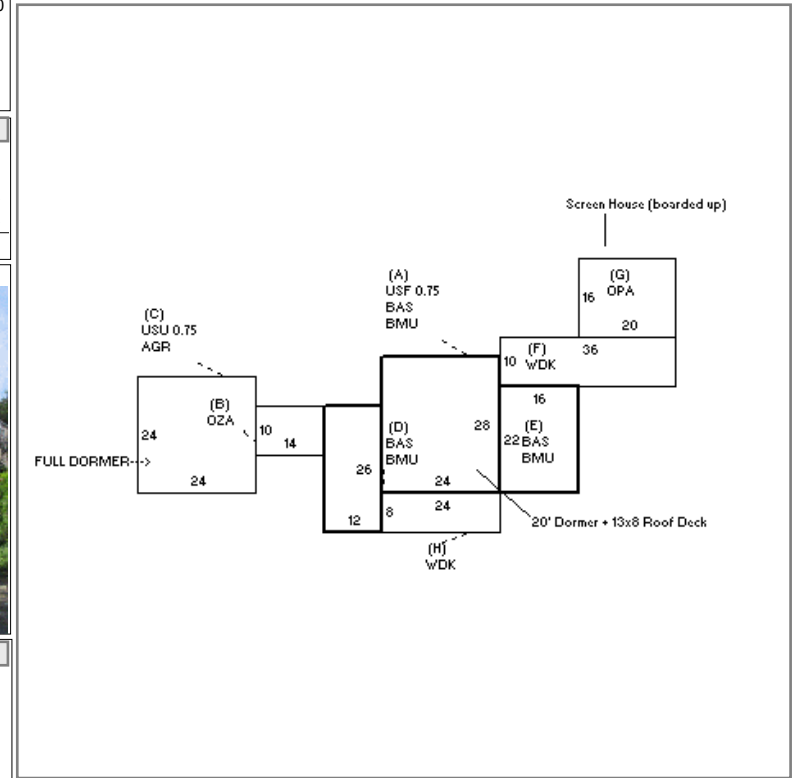

BUILDING	CD	ADJ	DESC	MEASURE	8/30/2018	LG
MODEL	1		RESIDENTIAL	LIST	11/16/2009	EST
STYLE	4	1.10	CAPE [100%]	REVIEW	12/3/2010	MR
QUALITY	+	1.15	GOOD-AVE+ [100%]			
FRAME	1	1.00	WOOD FRAME [100%]			

YEAR BLT	1992	SIZE ADJ	1.010	ELEMENT	CD	DESCRIPTION	ADJ	S	BAT	T	DESCRIPTION	UNITS	YB	ADJ PRICE	RCN
NET AREA	1,840	DETAIL ADJ	1.000	FOUNDATION			1.00	+	BMU	N	BSMT UNFINISHED	1,336		86.38	115,409
\$NLA(RCN)	\$565	OVERALL	1.120	EXT. COVER	1	WOOD SHINGLES	1.00	+	BAS	L	BAS AREA	1,336	1992	391.28	522,744
				ROOF SHAPE	1	GABLE	1.00	A	USF	L	UP-STRY FIN	504	1992	311.02	156,755
				ROOF COVER	1	ASPHALT SHINGLE	1.00	B	OZA	N	OPEN BRZWAY	140		69.73	9,762
				FLOOR COVER	1	HARDWOOD	1.00	C	AGR	N	ATTACHED GARAGE	576		117.57	67,720
				INT. FINISH	2	DRYWALL	1.00	C	USU	N	UPPER STORY UNF	432		173.02	74,743
				HEATING/COOLING	2	HOT WATER	1.02	+	WDK	N	ATT WOOD DECK	552		58.64	32,367
				FUEL SOURCE	1	OIL	1.00	G	OPA	N	OPEN PORCH	320		86.25	27,600
									WDK	N	ATT WOOD DECK	104		78.18	8,131
									F21	O	FPL 2S 1OP	1		19,573.00	19,573

TOTAL RCN	1,039,003	
CONDITION ELEM	CD	
EFF.YR/AGE	1992 / 30	
COND	30 30 %	
FUNC	0	
ECON	0	
DEPR	30 % GD	70
RCNLD	\$727,300	