

Key: 2280

Town of TRURO - Fiscal Year 2024

9/27/2023 7:11 pm SEQ #: 2.326

LEGAL

LAND

DETACHED

BUILDING

CURRENT OWNER				PARCEL ID				LOCATION			
GALVIN BRENDAN J PO BOX 383 TRURO, MA 02666-0383				46-52-0				5 LITTLE PAMET WAY			
TRANSFER HISTORY				DOS	T	SALE PRICE	BK-PG (Cert)				
GALVIN BRENDAN J				03/10/2009	99		23516-233				
GALVIN BRENDAN J IRREV TR				07/10/2008	99		23036-198				
GALVIN BRENDAN J				06/17/2008	99		22984-348				

CLASS	CLASS%	DESCRIPTION		BN ID	BN	CARD	
1010	100	SINGLE FAMILY			1	1 of 1	
PMT NO	PMT DT	TY	DESC	AMOUNT	INSP	BY	1st %
19-299X	09/30/2019	4	REHAB	8,410	03/10/2020	LG	100 100
FY2018		35	RES EXEMPT		10/01/2017		0 0
95-011	02/01/1995	6	SHED	1,200	06/26/1995		100 100
94-125	09/23/1994	2	ADDITION	50,000	06/26/1995		100 100

CD	T	AC/SF/UN	Nbhd	Inf1	Inf2	ADJ BASE	SAF	Inf3	Lpi	VC	CREDIT AMT	ADJ VALUE
100	A	0.775	14	1.00	1	1.00	1	1.00	RF1	1.75		488,390
300	A	0.825	14	1.00	1	1.00	1	1.00	RF1	1.75		39,700

TOTAL	1.600 Acres				ZONING	RES	FRNT	0	ASSESSED	CURRENT	PREVIOUS
Nbhd	TRURO CENTER				NOTE	VW SAME AS 46-53+54+55.			LAND	528,100	459,200
Inf1	NO ADJ					LAND			BUILDING	494,600	401,700
Inf2	NO ADJ					OTHER			DETACHED	2,200	2,100
									OTHER	0	0
									<b>TOTAL</b>	<b>1,024,900</b>	<b>863,000</b>

TY	QUAL	COND	DIM/NOTE	YB	UNITS	ADJ PRICE	RCNLD
SHF	A	1.00	A 0.75 12*12	1994	144	16.01	1,700
OSH	A	1.00	A 0.75 8*12		96	6.90	500



BLDG COMMENTS  
MARSH VW ADDED FY99 (NEVER ASSESSED).  
FY11 CHGS PER 11/09 M+L.

PER 11/09 M+L: BMF=2BR+BATH

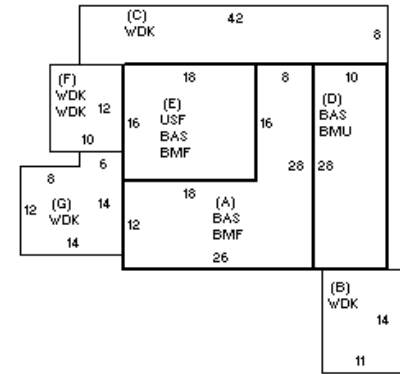

BUILDING	CD	ADJ	DESC	MEASURE	5/25/2016	FC	TOTAL RCN							727,354		
MODEL	1		RESIDENTIAL	LIST	5/25/2016	FC								CONDITION ELEM		CD
STYLE	8	1.10	CONTEMPORARY [100%]	REVIEW	12/16/2010	MR										
QUALITY	+	1.15	GOOD-AVE+ [100%]													
FRAME	1	1.00	WOOD FRAME [100%]													

YEAR BLT	1966	SIZE ADJ	1.030	ELEMENT	CD	DESCRIPTION	ADJ	S	BAT	T	DESCRIPTION	UNITS	YB	ADJ PRICE	RCN	TOTAL RCN
NET AREA	1,296	DETAIL ADJ	1.000	FOUNDATION			1.00	+	BMF	N	BSMT FINISH	728		178.24	129,755	
\$NLA(RCN)	\$561	OVERALL	1.130	EXT. COVER	1	WOOD SHINGLES	1.00	+	BAS	L	BAS AREA	1,008	1966	406.57	409,825	
				ROOF SHAPE	1	GABLE	1.00	+	WDK	N	ATT WOOD DECK	910		60.33	54,902	
				ROOF COVER	1	ASPHALT SHINGLE	1.00	D	BMU	N	BSMT UNFINISHED	280		109.34	30,615	
				FLOOR COVER	2	SOFTWOOD	1.00	E	USF	L	UP-STRY FIN	288	1966	321.63	92,629	
				INT. FINISH	5	OTHER	1.00		MST	O	MASONRY STACK	1		4,027.50	4,028	
				HEATING/COOLING	9	WARM/COOL AIR	1.03									
				FUEL SOURCE	1	OIL	1.00									

CAPACITY	UNITS	ADJ	EFF.YR/AGE	1980 / 42	
STORIES(FAR)	2	1.00	COND	32 32 %	
ROOMS	6	1.00	FUNC	0	
BEDROOMS	2	1.00	ECON	0	
BATHROOMS	2.5	1.00	DEPR	32	% GD 68
FIXTURES	8	\$5,600			
UNITS	0	1.00	RCNLD	\$494,600	