

Key: 2293

Town of TRURO - Fiscal Year 2024

9/27/2023 7:11 pm SEQ #: 2,340

LEGAL

CURRENT OWNER										PARCEL ID				LOCATION			
FINK CARL PO BOX 985 TRURO, MA 02666										46-65-0				7 ERLINDA RD			
TRANSFER HISTORY										DOS	T	SALE PRICE	BK-PG (Cert)				
FINK CARL										08/30/2016	QS	1,070,000	29899-140				
MYDELSKI PAUL A & IRREV QTIP TR OF 5/11/200										11/15/2004	QS	360,000	19241-6				
										10/16/2000	F		13298-082				

CLASS	CLASS%	DESCRIPTION			BN ID	BN	CARD	
1010	100	SINGLE FAMILY				1	1 of 1	
PMT NO	PMT DT	TY	DESC	AMOUNT	INSP	BY	1st	%
FY2018		35	RES EXEMPT		10/01/2017			0
16-161	07/26/2016	3	REPAIR/REMOD	75,000	01/26/2017	LG	100	100
06-146	06/30/2006	1	SINGLE FAM R	600,000	05/23/2008	JH	100	100

LAND

CD	T	AC/SF/UN	Nbhd	Inf1	Inf2	ADJ BASE	SAF	Inf3	Lpi	VC	CREDIT AMT	ADJ VALUE
100	A	0.775	14	1.00	1	1.00	1	1.00	R05	1.30		362,800
300	A	0.495	14	1.00	1	1.00	1	1.00	R05	1.30		17,700

DETACHED

TOTAL	1.270 Acres	ZONING	RES	FRNT	0	ASSESSED	CURRENT	PREVIOUS
Nbhd	TRURO CENTER	NOTE	LAND	380,500	292,700			
Inf1	NO ADJ		BUILDING	1,496,300	1,284,100			
Inf2	NO ADJ		DETACHED	0	0			
			OTHER	0	0			
			TOTAL	1,876,800	1,576,800			

BUILDING

TY	QUAL	COND	DIM/NOTE	YB	UNITS	ADJ PRICE	RCNLD

BUILDING	CD	ADJ	DESC	MEASURE	1/26/2017	LG
MODEL	1		RESIDENTIAL	LIST	5/15/2007	JH
STYLE	8	1.10	CONTEMPORARY [100%]	REVIEW	12/16/2010	MR
QUALITY	V	1.55	VERY GOOD [100%]			
FRAME	1	1.00	WOOD FRAME [100%]			

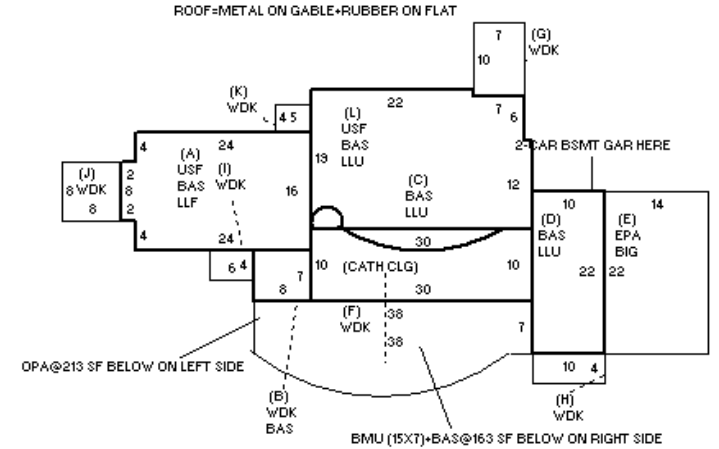

BLDG COMMENTS
(Chng of BR & BA from SVQ)

YEAR BLT	2006	SIZE ADJ	0.985	ELEMENT	CD	DESCRIPTION	ADJ	S	BAT	T	DESCRIPTION	UNITS	YB	ADJ PRICE	RCN
NET AREA	2,821	DETAIL ADJ	1.000	FOUNDATION	4	BSMT WALL	1.00	A	LLF	L	LOWER LEVEL FIN	400	2006	365.40	146,160
\$NLA(RCN)	\$631	OVERALL	1.150	EXT. COVER	1	WOOD SHINGLES	1.00	+	USF	L	UP-STRY FIN	945	2006	411.30	388,675
				ROOF SHAPE	1	GABLE	1.00	+	BAS	L	BAS AREA	1,476	2006	522.87	771,751
				ROOF COVER	9	OTHER	1.00	+	LLU	N	LOWER LEVEL UNF	1,020		258.07	263,227
				FLOOR COVER	1	HARDWOOD	1.00	E	BIG	N	BUILT-IN GARAGE	308		144.71	44,570
				INT. FINISH	1	PLASTER	1.00	E	EPA	N	ENCL PORCH	308		207.00	63,755
				HEATING/COOLING	10	HOT/COLD WATER	1.05	+	WDK	N	ATT WOOD DECK	683		79.14	54,053
				FUEL SOURCE	2	GAS	1.00	OPA	N	OPEN PORCH	213		123.26	26,254	
								GFP	O	GAS FIREPLACE	1		15,851.00	15,851	
								ODS	O	OUT DOOR SHOWER	1		0.00		

TOTAL RCN	1,781,296
CONDITION ELEM	CD
EFF.YR/AGE	2006 / 16
COND	16 16%
FUNC	0
ECON	0
DEPR	16 % GD 84
RCNLD	\$1,496,300