

Key: 2483

Town of TRURO - Fiscal Year 2024

9/27/2023 7:11 pm SEQ #: 2.544

LEGALS

DETACHED

BUILDING

CURRENT OWNER		PARCEL ID	LOCATION		
GABEL CAROLYN & BRETT LESLIE J C/O BRETT - 11 COBBS RD W HARTFORD, CT 06107		46-266-0	25 TOWN HALL RD		
TRANSFER HISTORY		DOS	T	SALE PRICE	BK-PG (Cert)
GABEL CAROLYN & BISHOP ALTHEA H ESTATE OF		12/28/1995	H	210,000	9990-085
		12/27/1995	99		9990-082

CD	T	AC/SF/UN	Nbhd	Inf1	Inf2	ADJ BASE	SAF	Inf3	Lpi	VC	CREDIT AMT	ADJ VALUE				
100	A	0.775	14	1.00	1	1.00	1	1.00	828,230	1.00	1	1.00	V8	2.30		641,880
300	A	0.605	14	1.00	1	1.00	1	1.00	63,250	1.00	1	1.00	V8	2.30		38,270

TOTAL	1.380 Acres	ZONING	RES	FRNT	0	ASSESSED	CURRENT	PREVIOUS
Nbhd	TRURO CENTER	NOTE				LAND	680,200	591,400
Inf1	NO ADJ		BUILDING	443,300	376,300			
Inf2	NO ADJ		DETACHED	1,200	1,100			
			OTHER	0	0	TOTAL	1,124,700	968,800

TY	QUAL	COND	DIM/NOTE	YB	UNITS	ADJ PRICE	RCNLD
SHF	A	1.00	A 0.75 8*12	2001	96	16.47	1,200



BLDG COMMENTS
 UNIT 1 (SEC A+E+I)=KITCH W/ STOVE+LR+2BR+2 HALF BATHS+SEP TUB; UNIT 2 (SEC C)=KITCH W/ STOVE+LR+BR+FULL BATH. HEAT=FHA+FWH (UNIT 1)+RINNAI HEATER (UNIT 2).

CLASS	CLASS%	DESCRIPTION		BN ID	BN	CARD		
1040	100	TWO FAMILY			1	1 of 1		
PMT NO	PMT DT	TY	DESC	AMOUNT	INSP	BY	1st	%
21-329X	09/20/2021	4	REHAB	11,850	11/23/2021	LG	100	100
18-260	08/16/2018	80	SOLAR TAXABL	17,400	11/14/2018	LG	100	100
09-093	05/27/2009	90	BP NVC	2,800	05/28/2010	JH	100	100
00-151	11/07/2000	3	REPAIR/REMOD	70,000	04/02/2002	BT	100	100
96-055	04/01/1996	9	DECK	2,500	06/01/1997		100	100

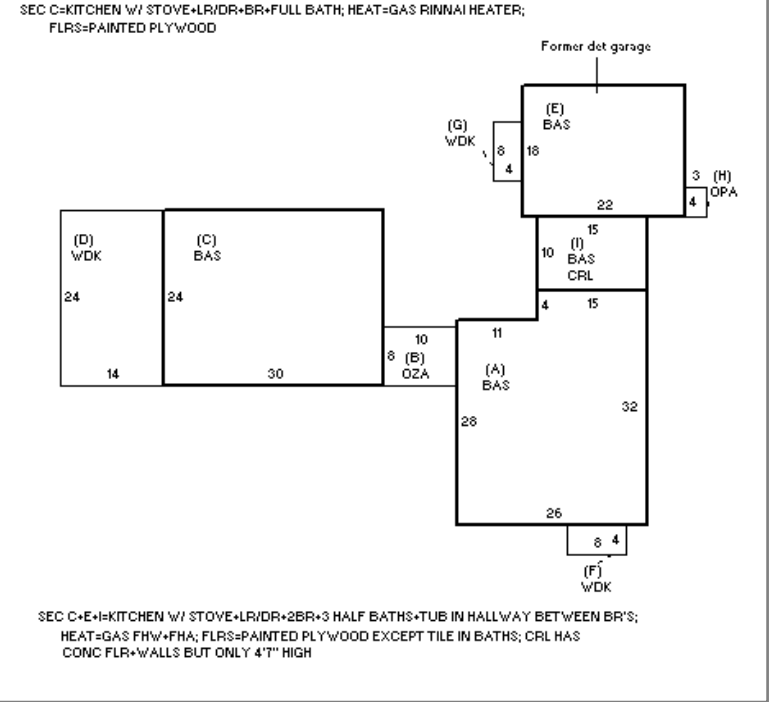

BUILDING	CD	ADJ	DESC	MEASURE	8/14/2015	FC
MODEL	1		RESIDENTIAL	LIST	9/10/2015	FC
STYLE	1	1.00	RANCH [100%]	REVIEW	11/29/2010	MR
QUALITY	A	1.00	AVERAGE [100%]			
FRAME	1	1.00	WOOD FRAME [100%]			

YEAR BLT	1961	SIZE ADJ	1.000	ELEMENT	CD	DESCRIPTION	ADJ
NET AREA	2,054	DETAIL ADJ	1.000	FOUNDATION	4	BSMT WALL	1.00
\$NLA(RCN)	\$308	OVERALL	0.969	EXT. COVER	1	WOOD SHINGLES	1.00
				ROOF SHAPE	1	GABLE	1.00
				ROOF COVER	1	ASPHALT SHINGLE	1.00
				FLOOR COVER	6	OTHER	1.00
				INT. FINISH	2	DRYWALL	1.00
				HEATING/COOLING	2	HOT WATER	1.02
				FUEL SOURCE	2	GAS	1.00

S	BAT	T	DESCRIPTION	UNITS	YB	ADJ PRICE	RCN
+	BAS	L	BAS AREA	2,054	1961	277.03	569,010
B	OZA	N	OPEN BRZWAY	80		59.73	4,778
+	WDK	N	ATT WOOD DECK	400		49.50	19,801
H	OPA	N	OPEN PORCH	12		136.07	1,633
I	CRL	N	CRAWL SPACE	150		39.74	5,961
F11	O		FPL 1S IOP	1		10,497.20	10,497
KIT	O		XTRA KITCHEN	1		16,064.10	16,064

TOTAL RCN	633,344
CONDITION ELEM	CD
EFF.YR/AGE	1990 / 32
COND	30 30 %
FUNC	0
ECON	0
DEPR	30 % GD 70
RCNLD	\$443,300