

Key: 2493

Town of TRURO - Fiscal Year 2024

9/27/2023 7:11 pm SEQ #: 2.558

LEGALS

LAND

DETACHED

BUILDING

CURRENT OWNER		PARCEL ID		LOCATION	
A AND M IRREVOCABLE TRUST C/O KOEHLER KAREN A & JEFFREY 12 MCTAGGART ST WESTBOROUGH, MA 01581-3568		46-276-0		14 BRIDGE RD	
TRANSFER HISTORY		DOS	T	SALE PRICE	BK-PG (Cert)
KOEHLER KAREN A & JEFFREY		02/13/2023	F	100	35636-197
A AND M IRREVOCABLE TRUST		03/05/2009	99		23502-148
GILL MARTIN & ANNETTE		03/24/1983	99		3697-210

CD	T	AC/SF/UN	Nbhd	Inf1	Inf2	ADJ BASE	SAF	Inf3	Lpi	VC	CREDIT AMT	ADJ VALUE
100	A	0.775	14	1.00	1	414,115	1.00	1	1.00	R03	1.15	320,940
300	A	0.365	14	1.00	1	31,625	1.00	1	1.00	R03	1.15	11,540

TOTAL	1.140 Acres	ZONING	RES	FRNT	0	ASSESSED	CURRENT	PREVIOUS
Nbhd	TRURO CENTER	N	OPA ON DGF WHICH IS ATT TO SFR BY WDK.			LAND	332,500	251,400
Inf1	NO ADJ	O	DGF=TRUSS CONSTRUCTION (NO ATTIC) PER			BUILDING	425,600	345,600
Inf2	NO ADJ	T	9/21/15 LIST.			DETACHED	10,600	10,000
		E				OTHER	0	0
						TOTAL	768,700	607,000

TY	QUAL	COND	DIM/NOTE	YB	UNITS	ADJ PRICE	RCNLD
SHF	A	1.00	A 0.75 8*12	1996	96	16.47	1,200
DGF	A	1.00	A 0.75 APPROX 20*24	1985	472	23.89	8,500
OPA	A	1.00	A 0.75 APPROX 4X24		104	11.00	900



BLDG COMMENTS		
MEASURE	8/24/2015	FC
LIST	9/21/2015	FC
REVIEW	11/29/2010	MR
No attic (truss construction; no stairs or floor)		

CLASS	CLASS%	DESCRIPTION		BN ID	BN	CARD		
1010	100	SINGLE FAMILY			1	1 of 1		
PMT NO	PMT DT	TY	DESC	AMOUNT	INSP	BY	1st	%
96-58	04/01/1996	6	SHED	1,300	06/01/1996		100	100

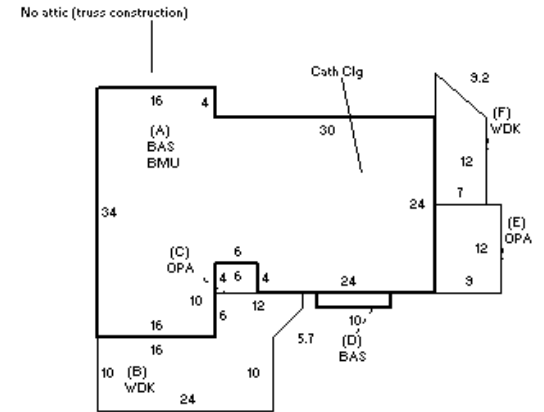

BUILDING	CD	ADJ	DESC	MEASURE	8/24/2015	FC
MODEL	1		RESIDENTIAL	LIST	9/21/2015	FC
STYLE	1	1.00	RANCH [100%]	REVIEW	11/29/2010	MR
QUALITY	+	1.15	GOOD-AVE+ [100%]			
FRAME	1	1.00	WOOD FRAME [100%]			

YEAR BLT	1985	SIZE ADJ	1.030
NET AREA	1,260	DETAIL ADJ	1.000
\$NLA(RCN)	\$490	OVERALL	1.030

CAPACITY		UNITS	ADJ
STORIES(FAR)	1	1.00	
ROOMS	4	1.00	
BEDROOMS	2	1.00	
BATHROOMS	2	1.00	
FIXTURES	6	\$4,200	
UNITS	1	1.00	

ELEMENT	CD	DESCRIPTION	ADJ
FOUNDATION	4	BSMT WALL	1.00
EXT. COVER	8	TEX PLYWOOD	1.00
ROOF SHAPE	1	GABLE	1.00
ROOF COVER	1	ASPHALT SHINGLE	1.00
FLOOR COVER	3	W/W CARPET	1.00
INT. FINISH	2	DRYWALL	1.00
HEATING/COOLING	9	WARM/COOL AIR	1.03
FUEL SOURCE	1	OIL	1.00

S	BAT	T	DESCRIPTION	UNITS	YB	ADJ PRICE	RCN
A	BMU	N	BSMT UNFINISHED	1,240		81.02	100,459
+	WDK	N	ATT WOOD DECK	409		58.66	23,992
+	OPA	N	OPEN PORCH	132		95.16	12,562
+	BAS	L	BAS AREA	1,260	1985	366.96	462,369
	F11	O	FPL 1S 1OP	1		13,216.60	13,217
	ODS	O	OUT DOOR SHOWER			0.00	

TOTAL RCN	616,798
CONDITION ELEM	CD
EFF.YR/AGE	1985 / 37
COND	31 31 %
FUNC	0
ECON	0
DEPR	31 % GD 69
RCNLD	\$425,600