

Key: 2531

Town of TRURO - Fiscal Year 2024

9/27/2023 7:11 pm SEQ #: 2.598

LEGALS

CURRENT OWNER				PARCEL ID				LOCATION			
OXTOBY KENNETH B & CORBIN JANE R PO BOX 30 TRURO, MA 02666-0030				46-326-0				12 GLACIER DR			
TRANSFER HISTORY				DOS	T	SALE PRICE	BK-PG (Cert)				
OXTOBY KENNETH B &				01/17/1992	QS	42,500	7840-322				

CLASS	CLASS%	DESCRIPTION			BN ID	BN	CARD	
1010	100	SINGLE FAMILY				1	1 of 1	
PMT NO	PMT DT	TY	DESC	AMOUNT	INSP	BY	1st	%
FY2018 17-090X	03/30/2017	35	RES EXEMPT		10/01/2017			0
		90	BP NVC	2,782	07/23/2018	JN	100	100
		20	NO PERMIT		07/28/2015	FC	100	100
10-262 95-073	12/20/2010	10	ALL OTHERS	1,500	02/23/2012	FC	100	100
	05/22/1995	1	SINGLE FAM R	145,000	07/08/1996		100	100

LAND

CD	T	AC/SF/UN	Nbhd	Inf1	Inf2	ADJ BASE	SAF	Inf3	Lpi	VC	CREDIT AMT	ADJ VALUE
100	A	0.775	12	1.00	1	1.00	1	1.00	R03	1.00		279,080
300	A	0.015	12	1.00	1	1.00	1	1.00	R03	1.00		410

TOTAL	34,413 SF	ZONING	RES	FRNT	0	ASSESSED	CURRENT	PREVIOUS
Nbhd	EAST TRURO	NOTE				LAND	279,500	243,000
Inf1	NO ADJ		BUILDING	734,000	631,400			
Inf2	NO ADJ		DETACHED	1,000	900			
			OTHER	0	0			
						<b>TOTAL</b>	<b>1,014,500</b>	<b>875,300</b>

DETACHED

TY	QUAL	COND	DIM/NOTE	YB	UNITS	ADJ PRICE	RCNLD
SHF	A	1.00	A 0.75 8*10		80	16.47	1,000

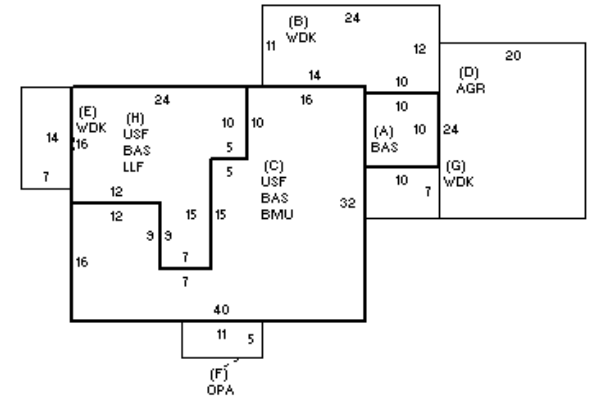

BUILDING

BUILDING	CD	ADJ	DESC	MEASURE	7/28/2015	FC
MODEL	1		RESIDENTIAL	LIST	11/19/2015	FC
STYLE	5	1.05	COLONIAL [100%]	REVIEW	12/15/2010	MR
QUALITY	A	1.00	AVERAGE [100%]			
FRAME	1	1.00	WOOD FRAME [100%]			

BLDG COMMENTS  
PER 11/19/15 LIST: WOODSTOVE ON HEARTH IN DEN OFF SAME CHIM AS FPL; LLF=FAM RM+FULL BATH (HEAT=BASEBOARD).

G

YEAR BLT	1995	SIZE ADJ	0.980	ELEMENT	CD	DESCRIPTION	ADJ	S	BAT	T	DESCRIPTION	UNITS	YB	ADJ PRICE	RCN	TOTAL RCN	1,005,520	
NET AREA	3,077	DETAIL ADJ	1.000	FOUNDATION	4	BSMT WALL	1.00	+	BAS	L	BAS AREA	1,380	1995	318.34	439,314			
\$NLA(RCN)	\$327	OVERALL	1.080	EXT. COVER	1	WOOD SHINGLES	1.00	+	WDK	N	ATT WOOD DECK	442		50.89	22,492			
				ROOF SHAPE	1	GABLE	1.00	C	BMU	N	BSMT UNFINISHED	863		76.31	65,856			
				ROOF COVER	1	ASPHALT SHINGLE	1.00	+	USF	L	UP-STRY FIN	1,280	1995	241.55	309,178			
				FLOOR COVER	1	HARDWOOD	1.00	D	AGR	N	ATTACHED GARAGE	480		100.00	48,001			
				INT. FINISH	2	DRYWALL	1.00	F	OPA	N	OPEN PORCH	55		107.32	5,903			
				HEATING/COOLING	9	WARM/COOL AIR	1.03	H	LLF	L	LOWER LEVEL FIN	417	1995	220.27	91,852			
				FUEL SOURCE	1	OIL	1.00		F21	O	FPL 2S 1OP	1		15,924.70	15,925			
																EFF.YR/AGE	1995 / 27	
																COND	27	27 %
																FUNC	0	
																ECON	0	
																DEPR	27	% GD 73
																RCNLD		\$734,000