

Key: 2571

Town of TRURO - Fiscal Year 2024

9/27/2023 7:11 pm SEQ #: 2.637

LEG
AL
LAND

| CURRENT OWNER | | PARCEL ID | | LOCATION | | | | | | | | |
|---|---|--------------------------|---------|------------------|------------------------|----------|------|------|-----|------|------------|-----------|
| BURHOE SHANE R & ADRIENNE S PO BOX 574 NO TRURO, MA 02652 | | 46-366-0 | | 1 LEFT HANDED RD | | | | | | | | |
| TRANSFER HISTORY | | DOS | T | SALE PRICE | BK-PG (Cert) | | | | | | | |
| BURHOE SHANE R & ADRIENNE BURHOE SHANE | | 02/11/2021 01/06/1997 | F QS | 100 58,500 | 33781-288 10558-092 | | | | | | | |
| CD | T | AC/SF/UN | Nbhd | Inf1 | Inf2 | ADJ BASE | SAF | Inf3 | Lpi | VC | CREDIT AMT | ADJ VALUE |
| 100 | A | 0.775 12 1.00 | 1 | 1.00 | 1.00 | 360,100 | 1.00 | 1.00 | R03 | 1.00 | | 279,080 |
| 300 | A | 0.425 12 1.00 | 1 | 1.00 | 1.00 | 27,500 | 1.00 | 1.00 | R03 | 1.00 | | 11,690 |

| CLASS | CLASS% | DESCRIPTION | | BN ID | BN | CARD | |
|--------|------------|---------------|--------------|---------|------------|--------|---------|
| 1010 | 100 | SINGLE FAMILY | | | 1 | 1 of 1 | |
| PMT NO | PMT DT | TY | DESC | AMOUNT | INSP | BY | 1st % |
| 22-497 | 12/06/2022 | 10 | ALL OTHERS | 50,000 | 06/09/2023 | LG | 100 100 |
| FY2018 | | 35 | RES EXEMPT | | 10/01/2017 | | 0 0 |
| 16-275 | 11/17/2016 | 70 | POOL | 20,000 | 07/23/2018 | LG | 100 100 |
| 97-052 | 05/01/1997 | 1 | SINGLE FAM R | 140,000 | 01/01/1999 | | 100 100 |

DE
TAC
HE
D

| TOTAL | 1.200 Acres | ZONING | RES | FRNT | 0 | ASSESSED | CURRENT | PREVIOUS |
|--------------|-------------|--------|--------------------------|------------------|------------------|----------|---------|----------|
| Nbhd | EAST TRURO | NOTE | HTB ON REAR DECK OF SFR. | | | LAND | 290,800 | 252,800 |
| Inf1 | NO ADJ | | LAND | 1,134,200 | 932,700 | | | |
| Inf2 | NO ADJ | | DETACHED | 23,900 | 22,900 | | | |
| | | | OTHER | 0 | 0 | | | |
| TOTAL | | | TOTAL | 1,448,900 | 1,208,400 | | | |

| TY | QUAL | COND | DIM/NOTE | YB | UNITS | ADJ PRICE | RCNLD |
|-----|------|------|--------------------|------|-------|-----------|--------|
| SHF | A | 1.00 | A 0.75 10*15 | | 150 | 16.01 | 1,800 |
| HTB | A | 1.00 | A 0.75 8*8 | | 1 | 2,730.40 | 2,000 |
| SPG | A | 1.00 | A 0.75 14*28 | 2017 | 392 | 43.47 | 12,800 |
| PTD | A | 1.00 | A 0.75 IRREG 48*48 | 2017 | 2,304 | 2.30 | 4,000 |
| PTD | A | 1.00 | A 0.75 32*60 | 2012 | 1,920 | 2.30 | 3,300 |



BLDG COMMENTS
PTD 32x60 = hockey rink

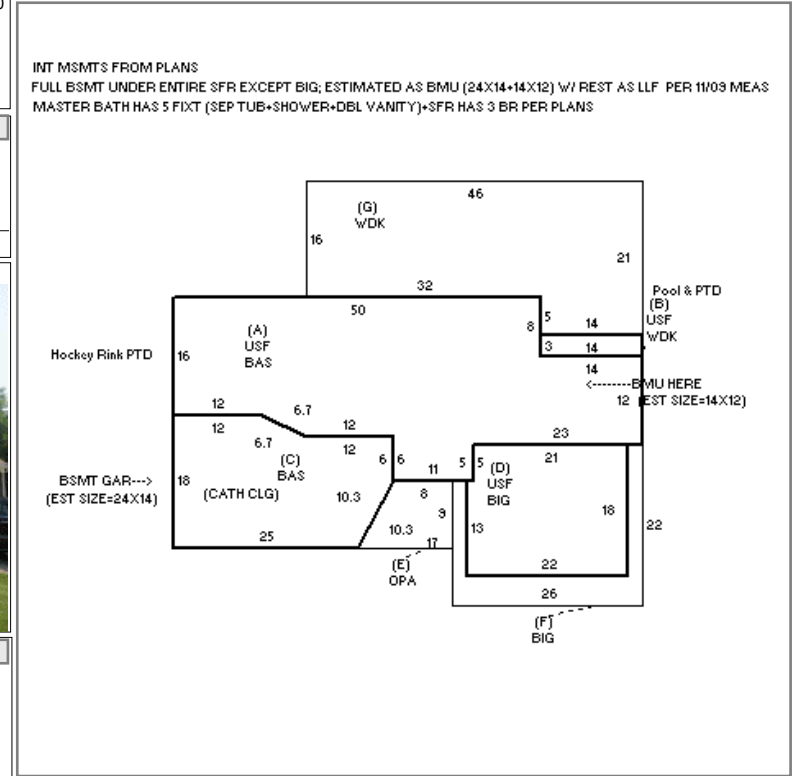

B
U
I
L
D
I
N
G

| BUILDING | CD | ADJ | DESC | MEASURE | 7/28/2015 | FC |
|----------|----|------|-------------------|---------|------------|-----|
| MODEL | 1 | | RESIDENTIAL | LIST | 7/28/2015 | EST |
| STYLE | 4 | 1.10 | CAPE [100%] | REVIEW | 12/15/2010 | MR |
| QUALITY | + | 1.15 | GOOD-AVE+ [100%] | | | |
| FRAME | 1 | 1.00 | WOOD FRAME [100%] | | | |

| YEAR BLT | 1997 | SIZE ADJ | 0.965 | ELEMENT | CD | DESCRIPTION | ADJ |
|--------------|-------|------------|---------|-----------------|----|-----------------|------|
| NET AREA | 4,319 | DETAIL ADJ | 1.000 | FOUNDATION | 4 | BSMT WALL | 1.00 |
| \$NLA(RCN) | \$350 | OVERALL | 1.130 | EXT. COVER | 1 | WOOD SHINGLES | 1.00 |
| CAPACITY | | | | ROOF SHAPE | 6 | SALTBOX | 1.00 |
| STORIES(FAR) | 1.75 | UNITS | 1.00 | ROOF COVER | 1 | ASPHALT SHINGLE | 1.00 |
| ROOMS | 0 | ADJ | 1.00 | FLOOR COVER | 1 | HARDWOOD | 1.00 |
| BEDROOMS | 4 | | 1.00 | INT. FINISH | 1 | PLASTER | 1.00 |
| BATHROOMS | 2.5 | | 1.00 | HEATING/COOLING | 9 | WARM/COOL AIR | 1.03 |
| FIXTURES | 10 | | \$7,000 | FUEL SOURCE | 1 | OIL | 1.00 |
| UNITS | 1 | | 1.00 | | | | |

| S | BAT | T | DESCRIPTION | UNITS | YB | ADJ PRICE | RCN |
|-----|-----|---|-----------------|-------|------|-----------|---------|
| A | BAS | L | BAS AREA | 1,148 | 1997 | 367.84 | 422,285 |
| + | USF | L | UP-STRY FIN | 1,581 | 1997 | 281.65 | 445,283 |
| + | WDK | N | ATT WOOD DECK | 848 | | 56.53 | 47,934 |
| C | BAS | L | BAS AREA | 473 | 1997 | 367.85 | 173,991 |
| + | BIG | N | BUILT-IN GARAGE | 557 | | 92.81 | 51,693 |
| E | OPA | N | OPEN PORCH | 95 | | 112.49 | 10,687 |
| LLF | L | L | LOWER LEVEL FIN | 1,117 | 1997 | 246.48 | 275,321 |
| BMU | N | N | BSMT UNFINISHED | 504 | | 102.44 | 51,629 |
| BMG | O | O | BSMT GARAGE | 1 | | 9,056.50 | 9,057 |
| F11 | O | O | FPL 1S IOP | 1 | | 13,584.80 | 13,585 |
| MST | O | O | MASONRY STACK | 1 | | 3,773.30 | 3,773 |
| ODS | O | O | OUT DOOR SHOWER | | | 0.00 | |

| TOTAL RCN | 1,512,237 |
|----------------|-------------|
| CONDITION ELEM | CD |
| EFF.YR/AGE | 1997 / 25 |
| COND | 25 25 % |
| FUNC | 0 |
| ECON | 0 |
| DEPR | 25 % GD 75 |
| RCNLD | \$1,134,200 |