

Key: 2581

Town of TRURO - Fiscal Year 2024

9/27/2023 7:11 pm SEQ #: 2.648

LEGAL

LAND

DETACHED

BUILDING

CURRENT OWNER				PARCEL ID				LOCATION			
CONTRINO MARIA L & ZALNASKY PAMELA S PO BOX 564 TRURO, MA 02666				47-5-0				1 FOURTH OF JULY RD			
TRANSFER HISTORY				DOS	T	SALE PRICE	BK-PG (Cert)				
CONTRINO MARIA L & SUGARMAN MARK J & PECKHAM GARDNER &				12/15/2020	QS	659,000	33579-114				
				10/14/2005	QS	640,000	20366-233				
				10/26/2001	QS	457,500	14369-249				

CLASS	CLASS%	DESCRIPTION			BN ID	BN	CARD	
1010	100	SINGLE FAMILY				1	1 of 1	
PMT NO	PMT DT	TY	DESC	AMOUNT	INSP	BY	1st	%
NP		20	NO PERMIT		09/21/2022	LG	100	100
22-142X	03/23/2022	90	BP NVC	5,900	09/21/2022	LG	100	100
21-077X	03/10/2021	4	REHAB	23,100	08/26/2021	LG	100	100
92-112	10/02/1992	9	DECK	500	06/18/1993		100	100
87-134	08/24/1987	1	SINGLE FAM R	149,000	12/31/1987		100	100

CD	T	AC/SF/UN	Nbhd	Inf1	Inf2	ADJ BASE	SAF	Inf3	Lpi	VC	CREDIT AMT	ADJ VALUE	
100	A	0.540	12	1.00	1	1.00	1.00	468,130	1.28	1	1.00	R07 1.30	324,580

TOTAL	23,522 SF	ZONING	RES	FRNT	0	ASSESSED	CURRENT	PREVIOUS
Nbhd	EAST TRURO	NOTE				LAND	324,600	282,200
Inf1	NO ADJ		BUILDING	647,500	529,200			
Inf2	NO ADJ		DETACHED	5,200	2,000			
						OTHER	0	0
TOTAL						977,300	813,400	

TY	QUAL	COND	DIM/NOTE	YB	UNITS	ADJ PRICE	RCNLD
HTB	A	1.00	A 0.75		1	2,730.40	2,000
SHF	G	1.18	G 0.90 12*16	2021	192	18.34	3,200



BLDG COMMENTS
Minisplit (2)

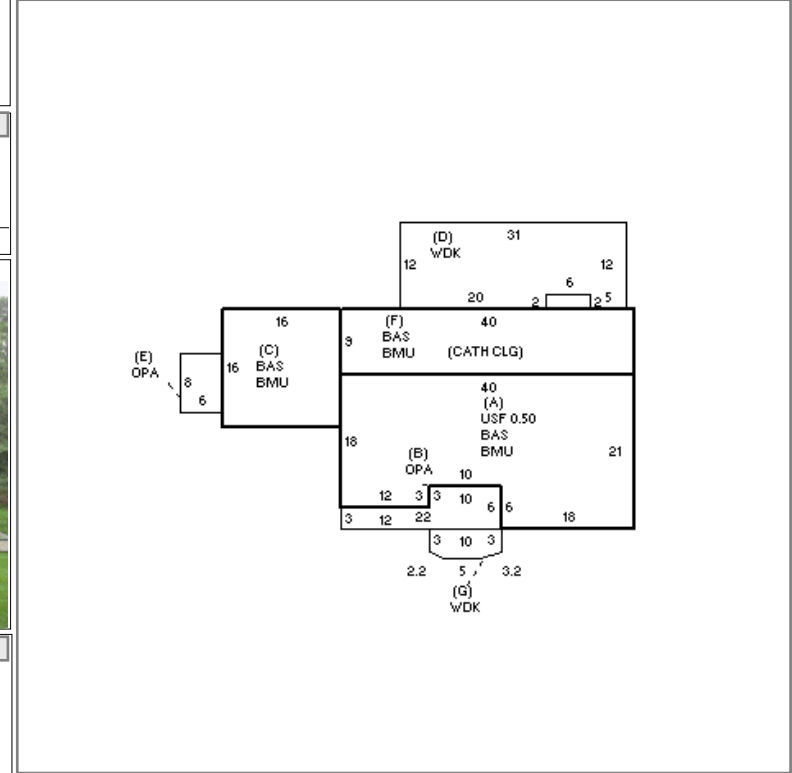

BUILDING	CD	ADJ	DESC	MEASURE	9/21/2022	LG
MODEL	1		RESIDENTIAL	LIST	9/21/2022	LG
STYLE	4	1.10	CAPE [100%]	REVIEW	12/6/2010	MR
QUALITY	G	1.35	GOOD [100%]			
FRAME	1	1.00	WOOD FRAME [100%]			

YEAR BLT	1988	SIZE ADJ	1.020	ELEMENT	CD	DESCRIPTION	ADJ	S	BAT	T	DESCRIPTION	UNITS	YB	ADJ PRICE	RCN
NET AREA	1,732	DETAIL ADJ	1.005	FOUNDATION	4	BSMT WALL	1.00	+	BMU	N	BSMT UNFINISHED	1,360		96.01	130,575
\$NLA(RCN)	\$534	OVERALL	1.050	EXT. COVER	1	WOOD SHINGLES	1.00	+	BAS	L	BAS AREA	1,000	1988	434.88	434,880
				ROOF SHAPE	1	GABLE	1.00	A	USF	L	UP-STRY FIN	372	1988	347.43	129,243
				ROOF COVER	1	ASPHALT SHINGLE	1.00	+	OPA	N	OPEN PORCH	144		112.78	16,240
				FLOOR COVER	1	HARDWOOD	1.00	+	WDK	N	ATT WOOD DECK	398		73.86	29,397
				INT. FINISH	2	DRYWALL	1.00	F	BAS	L	BAS AREA	360	1988	434.88	156,557
				HEATING/COOLING	5	ELECTRIC	0.95	F21	O	FPL 2S 1OP	1		21,754.30	21,754	
				FUEL SOURCE	3	ELECTRIC	1.00	GEN	O	GENERATOR	1		0.00		
								ODS	O	OUT DOOR SHOWER	1		0.00		

TOTAL RCN	924,945
CONDITION ELEM	CD
EFF.YR/AGE	1988 / 34
COND	30 30 %
FUNC	0
ECON	0
DEPR	30 % GD 70
RCNLD	\$647,500