

Key: 2586

Town of TRURO - Fiscal Year 2024

9/27/2023 7:11 pm SEQ #: 2.654

LEG
AL

| CURRENT OWNER | | PARCEL ID | | LOCATION | |
|---|--|------------|----|------------------|--------------|
| BRADFORD THEODORE H & HANEY GILLIAN A 26 LEE ST JAMAICA PLAIN, MA 02130 | | 47-10-0 | | 68 OLD KINGS HWY | |
| TRANSFER HISTORY | | DOS | T | SALE PRICE | BK-PG (Cert) |
| BRADFORD THEODORE H & LAFRANCE DIANE B | | 03/15/2019 | QS | 650,000 | 31891-233 |
| | | 08/03/1981 | 99 | | 3335-166+ |

| CLASS | CLASS% | DESCRIPTION | | BN ID | BN | CARD | |
|--------|------------|---------------|-----------|--------|------------|--------|---------|
| 1010 | 100 | SINGLE FAMILY | | | 1 | 1 of 1 | |
| PMT NO | PMT DT | TY | DESC | AMOUNT | INSP | BY | 1st % |
| SS22 | 10/24/2005 | 50 | SPLIT SUB | | | | 100 100 |
| 02-211 | 10/18/2002 | 90 | BP NVC | 5,000 | 05/22/2007 | JH | 100 100 |
| 99-177 | 10/01/1999 | 6 | SHED | 1,722 | 05/01/2000 | | 100 100 |
| 98-126 | 07/01/1998 | 6 | SHED | 1,900 | 06/01/1999 | | 100 100 |
| 85-090 | 07/19/1985 | 7 | GARAGE | | 12/31/1988 | SW | 100 100 |

LAN
D

| CD | T | AC/SF/UN | Nbhd | Inf1 | Inf2 | ADJ BASE | SAF | Inf3 | Lpi | VC | CREDIT AMT | ADJ VALUE |
|-----|---|----------|------|------|------|----------|-----|------|-----|------|------------|-----------|
| 100 | A | 0.775 | 12 | 1.00 | 1 | 1.00 | 1 | 1.00 | R07 | 1.30 | | 362,800 |
| 300 | A | 0.531 | 12 | 1.00 | 1 | 1.00 | 1 | 1.00 | R07 | 1.30 | | 18,980 |

DET
ACH
ED

| | | | | | | | | |
|-------|-------------|--|----------|---------|---------|----------|---------|----------|
| TOTAL | 1.306 Acres | ZONING | RES | FRNT | 0 | ASSESSED | CURRENT | PREVIOUS |
| Nbhd | EAST TRURO | NOTE 3/15/19 Acreage chnged per deed Bk 31891 Pg 233. FY07 REDUCED ACREAGE PER 2005 SUBDIV PLAN. | LAND | 381,800 | 332,000 | | | |
| Inf1 | NO ADJ | | BUILDING | 532,400 | 432,200 | | | |
| Inf2 | NO ADJ | | DETACHED | 29,600 | 28,100 | | | |
| | | | OTHER | 0 | 0 | | | |
| TOTAL | | | TOTAL | 943,800 | 792,300 | | | |

| TY | QUAL | COND | DIM/NOTE | YB | UNITS | ADJ PRICE | RCNLD |
|-----|------|------|---------------|------|-------|-----------|--------|
| SHF | A | 1.00 | A 0.75 8*12 | 1999 | 96 | 16.47 | 1,200 |
| SHF | A | 1.00 | A 0.75 10*12 | 1998 | 120 | 16.01 | 1,400 |
| GUS | G | 1.18 | A- 0.70 20*24 | 1985 | 480 | 74.36 | 25,000 |
| WDK | G | 1.18 | A- 0.70 12X12 | 1985 | 144 | 12.98 | 1,300 |
| WDK | A | 1.00 | A 0.75 8*10 | | 80 | 11.00 | 700 |

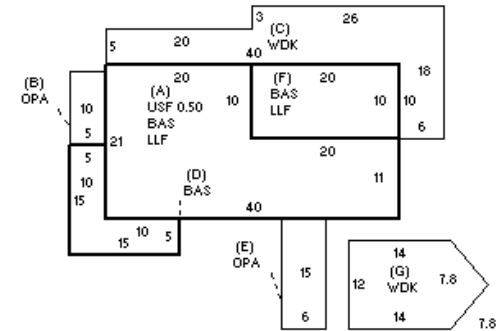

B
U
I
L
D
I
N
G

| BUILDING | CD | ADJ | DESC | MEASURE | 8/13/2015 | FC |
|----------|----|------|-------------------|---------|------------|-----|
| MODEL | 1 | | RESIDENTIAL | LIST | 8/13/2015 | EST |
| STYLE | 4 | 1.10 | CAPE [100%] | REVIEW | 12/15/2010 | MR |
| QUALITY | + | 1.15 | GOOD-AVE+ [100%] | | | |
| FRAME | 1 | 1.00 | WOOD FRAME [100%] | | | |

BLDG COMMENTS
 ODS ON GARAGE. CHECK IN NEXT LIST IF SEC F
 BAS IS CATH CLG.

| YEAR BLT | 1982 | SIZE ADJ | 1.000 | ELEMENT | CD | DESCRIPTION | ADJ | S | BAT | T | DESCRIPTION | UNITS | YB | ADJ PRICE | RCN | TOTAL RCN | 771,665 | | |
|--------------|-------|------------|---------|-----------------|----|-----------------|------|-----|-----|-----------------|-----------------|-------|------|-----------|---------|----------------|---------|------------|------------|
| NET AREA | 2,125 | DETAIL ADJ | 1.000 | FOUNDATION | 4 | BSMT WALL | 1.00 | + | LLF | L | LOWER LEVEL FIN | 840 | 1982 | 258.13 | 216,826 | CONDITION ELEM | CD | | |
| \$NLA(RCN) | \$363 | OVERALL | 1.120 | EXT. COVER | 1 | WOOD SHINGLES | 1.00 | A | USF | L | UP-STRY FIN | 320 | 1982 | 309.50 | 99,040 | | | | |
| | | | | ROOF SHAPE | 1 | GABLE | 1.00 | + | OPA | N | OPEN PORCH | 140 | | 100.46 | 14,065 | | | | |
| | | | | ROOF COVER | 1 | ASPHALT SHINGLE | 1.00 | + | WDK | N | ATT WOOD DECK | 566 | | 58.06 | 32,860 | | | | |
| | | | | FLOOR COVER | 1 | HARDWOOD | 1.00 | + | BAS | L | BAS AREA | 965 | 1982 | 391.24 | 377,545 | | | | |
| | | | | INT. FINISH | 2 | DRYWALL | 1.00 | F22 | O | FPL 2S 2OP | 1 | | | 27,130.40 | 27,130 | | | | |
| | | | | HEATING/COOLING | 3 | RADIANT | 1.02 | ODS | O | OUT DOOR SHOWER | 1 | | | 0.00 | | | | | |
| | | | | FUEL SOURCE | 3 | ELECTRIC | 1.00 | | | | | | | | | | | | |
| CAPACITY | | UNITS | ADJ | | | | | | | | | | | | | | | TOTAL RCN | 771,665 |
| STORIES(FAR) | | 1.5 | 1.00 | | | | | | | | | | | | | | | EFF.YR/AGE | 1983 / 39 |
| ROOMS | | 0 | 1.00 | | | | | | | | | | | | | | | COND | 31 31 % |
| BEDROOMS | | 3 | 1.00 | | | | | | | | | | | | | | | FUNC | 0 |
| BATHROOMS | | 2 | 1.00 | | | | | | | | | | | | | | | ECON | 0 |
| FIXTURES | | 6 | \$4,200 | | | | | | | | | | | | | | | DEPR | 31 % GD 69 |
| UNITS | | 1 | 1.00 | | | | | | | | | | | | | | | RCNLD | \$532,400 |