

Key: 2593

Town of TRURO - Fiscal Year 2024

9/27/2023 7:11 pm SEQ #: 2.661

LEGALS

CURRENT OWNER										PARCEL ID			LOCATION			
DELUCA REV TRUST TRS: DELUCA JAMES G ET AL 82 SCHOOL STREET MIDDLEBORO, MA 02346										47-17-0			8 DEER PATH			
TRANSFER HISTORY										DOS	T	SALE PRICE	BK-PG (Cert)			
DELUCA REV TRUST										03/12/2015	F		(205719)			
DELUCA JAMES G & PAMELA J										01/07/2011	QS	565,000	(193368)			
PURDY BRUCE J &										07/22/2008	O	440,000	(186510)			

CLASS	CLASS%	DESCRIPTION			BN ID	BN	CARD	
1010	100	SINGLE FAMILY				1	1 of 1	
PMT NO	PMT DT	TY	DESC	AMOUNT	INSP	BY	1st	%
20-074	03/02/2020	2	ADDITION	20,000	11/09/2020	LG	100	100
19-392	11/25/2019	3	REPAIR/REMOD	120,000	01/23/2020	LG	100	100
15-121	05/15/2015	3	REPAIR/REMOD	15,000	10/01/2015	FC	100	100
08-156	08/19/2008	3	REPAIR/REMOD	65,000	10/21/2008	FC	100	100
90-011	02/02/1990	10	ALL OTHERS	22,000	05/08/1991		100	100

LAND

CD	T	AC/SF/UN	Nbhd	Inf1	Inf2	ADJ BASE	SAF	Inf3	Lpi	VC	CREDIT AMT	ADJ VALUE
100	A	0.775	12	1.00	1	1.00	1	1.00	R05	1.00		279,080
300	A	0.065	12	1.00	1	1.00	1	1.00	R05	1.00		1,790

DETACHED

TOTAL	36,591 SF	ZONING	RES	FRNT	0	ASSESSED	CURRENT	PREVIOUS
Nbhd	EAST TRURO	NOTE				LAND	280,900	244,200
Inf1	NO ADJ		BUILDING	775,800	637,000			
Inf2	NO ADJ		DETACHED	0	0			
			OTHER	0	0			
						<b>TOTAL</b>	<b>1,056,700</b>	<b>881,200</b>

TY	QUAL	COND	DIM/NOTE	YB	UNITS	ADJ PRICE	RCNLD	PHOTO	11/09/2020
									

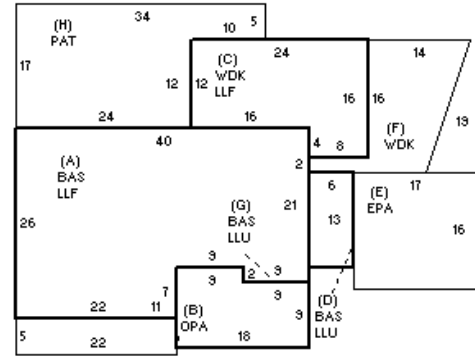

BUILDING

BUILDING	CD	ADJ	DESC	MEASURE	7/8/2014	FC
MODEL	1		RESIDENTIAL	LIST	2/2/2016	FC
STYLE	1	1.00	RANCH [100%]	REVIEW	4/5/2021	MR
QUALITY	+	1.15	GOOD-AVE+ [100%]			
FRAME	1	1.00	WOOD FRAME [100%]			

**BLDG COMMENTS**  
LLF=FAM RM+2 BR'S+FULL BATH; HAS BB HEAT+ MINI-SPLITS IN FAM RM+BR'S.

INDING

YEAR BLT	1977	SIZE ADJ	0.995	ELEMENT	CD	DESCRIPTION	ADJ	S	BAT	T	DESCRIPTION	UNITS	YB	ADJ PRICE	RCN	TOTAL RCN	881,639
NET AREA	2,442	DETAIL ADJ	1.000	FOUNDATION	4	BSMT WALL	1.00	+	LLF	L	LOWER LEVEL FIN	1,252	1977	233.84	292,764		
\$NLA(RCN)	\$361	OVERALL	1.050	EXT. COVER	1	WOOD SHINGLES	1.00	+	BAS	L	BAS AREA	1,190	1977	364.95	434,293		
				ROOF SHAPE	1	GABLE	1.00	B	OPA	N	OPEN PORCH	110		93.71	10,309		
				ROOF COVER	1	ASPHALT SHINGLE	1.00	+	LLU	N	LOWER LEVEL UNF	258		186.98	48,241		
				FLOOR COVER	1	HARDWOOD	1.00	E	EPA	N	ENCL PORCH	272		149.98	40,795		
				INT. FINISH	2	DRYWALL	1.00	+	WDK	N	ATT WOOD DECK	534		54.16	28,919		
				HEATING/COOLING	11	HOT WAT.-CL AIR	1.05	H	PAT	N	PATIO	458		16.82	7,704		
				FUEL SOURCE	1	OIL	1.00		F11	O	FPL 1S 1OP	1		13,015.40	13,015		
									ODS	O	OUT DOOR SHOWER			0.00			

CONDITION ELEM	CD
EFF.YR/AGE	2010 / 12
COND	12 12 %
FUNC	0
ECON	0
DEPR	12 % GD 88
RCNLD	\$775,800