

Key: 2606

Town of TRURO - Fiscal Year 2024

9/27/2023 7:11 pm SEQ #: 2.675

LEGALS

| CURRENT OWNER | | | | PARCEL ID | | | | LOCATION | | | | |
|--|---|----------|------|------------|------|------------|------|--------------|------|-----|------------|-----------|
| TOMLINSON DIANE CARVALHO 33 MILAN RD WOODBIDGE, CT 06525 | | | | 47-30-0 | | | | 6 DEER PATH | | | | |
| TRANSFER HISTORY | | | | DOS | T | SALE PRICE | | BK-PG (Cert) | | | | |
| TOMLINSON DIANE CARVALHO | | | | 01/15/2010 | 99 | (190538) | | (190538) | | | | |
| MINER CHRISTOPHER R | | | | 01/15/2010 | 99 | (190537) | | (190537) | | | | |
| CARVALHO GEORGE L JR & DI | | | | 01/20/2000 | QS | 330,000 | | (156359) | | | | |
| CD | T | AC/SF/UN | Nbhd | Inf1 | Inf2 | ADJ BASE | SAF | Inf3 | Lpi | VC | CREDIT AMT | ADJ VALUE |
| 100 | A | 0.620 | 12 | 1.00 | 1 | 360,100 | 1.17 | 1 | 1.00 | R05 | | 260,500 |

| CLASS | CLASS% | DESCRIPTION | | | BN ID | BN | CARD | |
|---------|------------|---------------|--------------|--------|------------|----|--------|-----|
| 1010 | 100 | SINGLE FAMILY | | | | 1 | 1 of 1 | |
| PMT NO | PMT DT | TY | DESC | AMOUNT | INSP | BY | 1st | % |
| 18-289X | 09/06/2018 | 4 | REHAB | 7,187 | 04/02/2019 | LG | 100 | 100 |
| 16-007 | 01/06/2016 | 90 | BP NVC | 4,636 | 12/19/2016 | LG | 100 | 100 |
| 86-062 | 04/07/1986 | 1 | SINGLE FAM R | | 12/31/1986 | SW | 100 | 100 |

LAND

| TOTAL | 27,007 SF | ZONING | RES | FRNT | 0 | ASSESSED | CURRENT | PREVIOUS |
|-------|------------|--------|----------|---------|---------|--------------|----------------|----------------|
| Nbhd | EAST TRURO | NOTE | | | | LAND | 260,500 | 226,500 |
| Inf1 | NO ADJ | | BUILDING | 494,300 | 425,400 | | | |
| Inf2 | NO ADJ | | DETACHED | 0 | 0 | | | |
| | | | OTHER | 0 | 0 | | | |
| | | | | | | TOTAL | 754,800 | 651,900 |

DETACHED

| TY | QUAL | COND | DIM/NOTE | YB | UNITS | ADJ PRICE | RCNLD |
|----|------|------|----------|----|-------|-----------|-------|
| | | | | | | | |

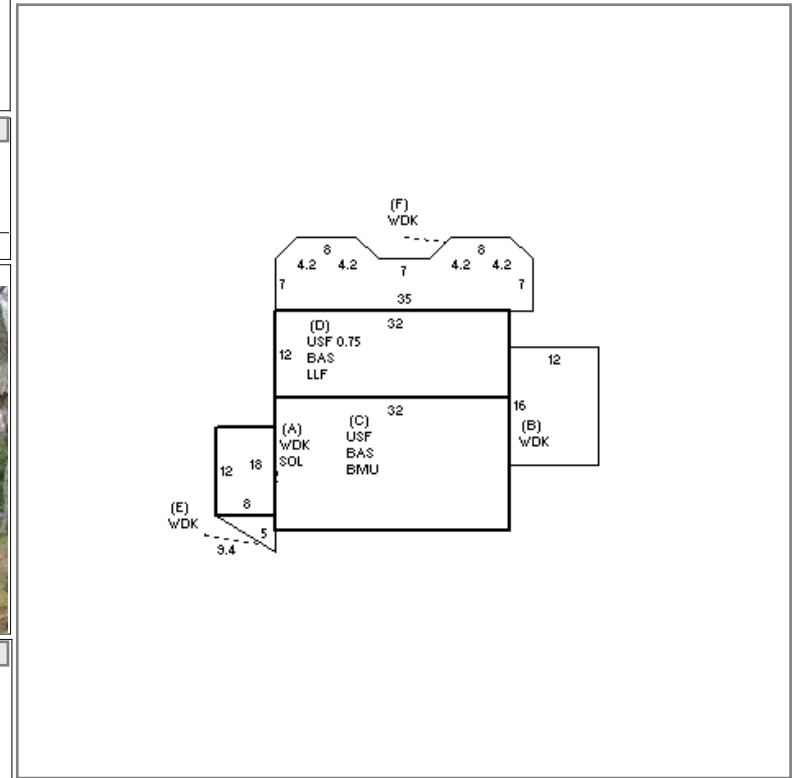

BUILDING

| BUILDING | CD | ADJ | DESC | MEASURE | 5/17/2016 | FC |
|----------|----|------|-------------------|---------|------------|-----|
| MODEL | 1 | | RESIDENTIAL | LIST | 5/17/2016 | EST |
| STYLE | 5 | 1.05 | COLONIAL [100%] | REVIEW | 12/15/2010 | MR |
| QUALITY | A | 1.00 | AVERAGE [100%] | | | |
| FRAME | 1 | 1.00 | WOOD FRAME [100%] | | | |

BLDG COMMENTS
FY03=CORRECTED STYLE FROM CAPE TO CONTEMP. FY11 CHNGS PER 12/09 MEAS (F21 TO MST PER WDSTV).

G

| YEAR BLT | 1986 | SIZE ADJ | 0.995 | ELEMENT | CD | DESCRIPTION | ADJ | S | BAT | T | DESCRIPTION | UNITS | YB | ADJ PRICE | RCN | TOTAL RCN | 716.357 |
|--------------|-------|-----------------|-------|-----------------|----|-----------------|------|-----|-----|---|-----------------|-------|------|-----------|---------|----------------|------------|
| NET AREA | 2,304 | DETAIL ADJ | 1.000 | FOUNDATION | 4 | BSMT WALL | 1.00 | A | SOL | L | SOLARIUM | 96 | 1986 | 188.86 | 18,131 | CONDITION ELEM | CD |
| \$NLA(RCN) | \$311 | OVERALL | 1.070 | EXT. COVER | 1 | WOOD SHINGLES | 1.00 | + | WDK | N | ATT WOOD DECK | 619 | | 47.99 | 29,705 | | |
| CAPACITY | | | | ROOF SHAPE | 1 | GABLE | 1.00 | C | BMU | N | BSMT UNFINISHED | 576 | | 86.97 | 50,095 | | |
| STORIES(FAR) | 1.75 | ROOF COVER | 1.00 | ROOF COVER | 1 | ASPHALT SHINGLE | 1.00 | + | BAS | L | BAS AREA | 960 | 1986 | 323.39 | 310,458 | | |
| ROOMS | 0 | FLOOR COVER | 1.00 | FLOOR COVER | 3 | W/W CARPET | 1.00 | + | USF | L | UP-STRY FIN | 864 | 1986 | 249.40 | 215,481 | | |
| BEDROOMS | 4 | INT. FINISH | 1.00 | INT. FINISH | 2 | DRYWALL | 1.00 | D | LLF | L | LOWER LEVEL FIN | 384 | 1986 | 221.57 | 85,084 | | |
| BATHROOMS | 2 | HEATING/COOLING | 1.00 | HEATING/COOLING | 2 | HOT WATER | 1.02 | MST | O | O | MASONRY STACK | 1 | | 3,203.50 | 3,204 | | |
| FIXTURES | 6 | FUEL SOURCE | 1.00 | FUEL SOURCE | 2 | GAS | 1.00 | ODS | O | O | OUT DOOR SHOWER | | | 0.00 | | | |
| UNITS | 0 | | | | | | | | | | | | | | | | |
| | | | | | | | | | | | | | | | | EFF.YR/AGE | 1987 / 35 |
| | | | | | | | | | | | | | | | | COND | 31 31 % |
| | | | | | | | | | | | | | | | | FUNC | 0 |
| | | | | | | | | | | | | | | | | ECON | 0 |
| | | | | | | | | | | | | | | | | DEPR | 31 % GD 69 |
| | | | | | | | | | | | | | | | | RCNLD | \$494,300 |