

Key: 2612

Town of TRURO - Fiscal Year 2024

9/27/2023 7:11 pm SEQ #: 2.683

LEGAL

CURRENT OWNER				PARCEL ID				LOCATION			
GOLDEN JAMES F & KEPLER-GOLDEN VALERIE PO BOX 2035 TRURO, MA 02666-2035				47-36-0				7 BAYBERRY LN			
				TRANSFER HISTORY				DOS	T	SALE PRICE	BK-PG (Cert)
				GOLDEN JAMES F & GOLDEN JAMES F				04/04/2011	99	(193960)	
				YOUNGBLOOD ROBERT J & PAT				10/03/2000	P	93,000	(159266)
								06/15/2000	R	82,500	(158067)

CLASS	CLASS%	DESCRIPTION			BN ID	BN	CARD	
1010	100	SINGLE FAMILY				1	1 of 1	
PMT NO	PMT DT	TY	DESC	AMOUNT	INSP	BY	1st	%
19-188X	06/21/2019	4	REHAB	17,000	07/13/2020	LG	100	100
19-131X	05/01/2019	4	REHAB		07/02/2019	LG	100	100
FY2018		35	RES EXEMPT		10/01/2017		0	0
00-171	12/01/2000	1	SINGLE FAM R	450,000	04/10/2002	BT	100	100
00-021	03/01/2000	1	SINGLE FAM R	100,000	12/31/2000		100	100

LAND

CD	T	AC/SF/UN	Nbhd	Inf1	Inf2	ADJ BASE	SAF	Inf3	Lpi	VC	CREDIT AMT	ADJ VALUE
100	A	0.620	12	1.00	1	1.00	1	1.00	R05	1.00		260,500

TOTAL	27,007 SF	ZONING	RES	FRNT	0	ASSESSED	CURRENT	PREVIOUS
Nbhd	EAST TRURO	NOTE				LAND	260,500	226,500
Inf1	NO ADJ		BUILDING	672,100	552,200			
Inf2	NO ADJ		DETACHED	0	0			
			OTHER	0	0			
						TOTAL	932,600	778,700

DETACHED

TY	QUAL	COND	DIM/NOTE	YB	UNITS	ADJ PRICE	RCNLD	PHOTO
								07/13/2020



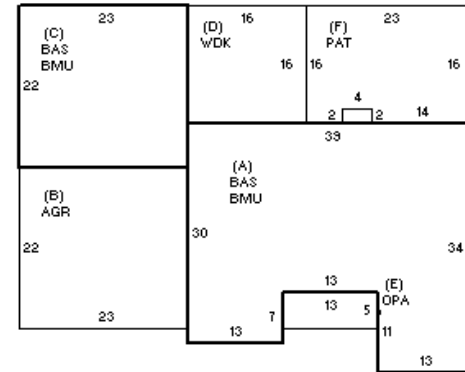

BUILDING

BUILDING	CD	ADJ	DESC	MEASURE	7/13/2020	LG
MODEL	1		RESIDENTIAL	LIST	7/13/2020	C19
STYLE	1	1.00	RANCH [100%]	REVIEW	12/15/2010	MR
QUALITY	+	1.15	GOOD-AVE+ [100%]	7/13/2020 Interior data confirmed and added to by owner at door (C-19).		
FRAME	1	1.00	WOOD FRAME [100%]			

YEAR BLT	2001	SIZE ADJ	1.020	ELEMENT	CD	DESCRIPTION	ADJ	S	BAT	T	DESCRIPTION	UNITS	YB	ADJ PRICE	RCN	TOTAL RCN	800,177
NET AREA	1,637	DETAIL ADJ	1.000	FOUNDATION	4	BSMT WALL	1.00	+	BMU	N	BSMT UNFINISHED	1,637		74.79	122,434		
\$NLA(RCN)	\$489	OVERALL	1.020	EXT. COVER	2	CLAPBOARD	1.00	+	BAS	L	BAS AREA	1,637	2001	350.96	574,523		
				ROOF SHAPE	1	GABLE	1.00	B	AGR	N	ATTACHED GARAGE	506		110.59	55,958		
				ROOF COVER	1	ASPHALT SHINGLE	1.00	D	WDK	N	ATT WOOD DECK	256		64.72	16,567		
				FLOOR COVER	1	HARDWOOD	1.00	E	OPA	N	OPEN PORCH	65		121.32	7,886		
				INT. FINISH	2	DRYWALL	1.00	F	PAT	N	PATIO	360		17.80	6,407		
				HEATING/COOLING	2	HOT WATER	1.02		GFP	O	GAS FIREPLACE	1		10,801.60	10,802		
				FUEL SOURCE	2	GAS	1.00										

TOTAL RCN		800,177	
CONDITION ELEM		CD	
EFF.YR/AGE	2006 / 16		
COND	16	16	%
FUNC	0		
ECON	0		
DEPR	16	% GD	84
RCNLD	\$672,100		