

Key: 2647

Town of TRURO - Fiscal Year 2024

9/27/2023 7:11 pm SEQ #: 2.720

LEGAL

CURRENT OWNER		PARCEL ID		LOCATION	
THEODORE STEPHEN GEORGE 989 MEMORIAL DR CAMBRIDGE, MA 02138		47-72-0		17 CRANBERRY LN	
TRANSFER HISTORY		DOS	T	SALE PRICE	BK-PG (Cert)
THEODORE STEPHEN GEORGE		09/20/2004	99		(174444)
D K REALTY TRUST		08/04/1988	99		(115034)

CLASS	CLASS%	DESCRIPTION		BN ID	BN	CARD	
1010	100	SINGLE FAMILY			1	1 of 1	
PMT NO	PMT DT	TY	DESC	AMOUNT	INSP	BY	1st %
22-507	12/21/2022	4	REHAB	48,000	06/22/2023	LG	100 100
20-216	08/17/2020	80	SOLAR TAXABL	89,000	12/15/2020	LG	100 100
19-096X	04/09/2019	90	BP NVC	966	11/19/2019	LG	100 100
09-126	07/16/2009	10	ALL OTHERS	20,300	05/25/2010	JH	100 100
89-152	10/13/1989	2	ADDITION	40,000	12/31/1989		100 100

LAND

CD	T	AC/SF/UN	Nbhd	Infl1	Infl2	ADJ BASE	SAF	Infl3	Lpi	VC	CREDIT AMT	ADJ VALUE
100	A	0.775	12	1.00	1	1.00	1	1.00	R05	1.00		279,080
300	A	0.375	12	1.00	1	1.00	1	1.00	R05	1.00		10,310

TOTAL	1.150 Acres	ZONING	RES	FRNT	0	ASSESSED	CURRENT	PREVIOUS
Nbhd	EAST TRURO	NOTE				LAND	289,400	251,600
Infl1	NO ADJ		LAND	741,200	601,700			
Infl2	NO ADJ		BUILDING	0	0			
			DETACHED	0	0			
			OTHER	0	0			
			TOTAL	1,030,600	853,300			

DETACHED

TY	QUAL	COND	DIM/NOTE	YB	UNITS	ADJ PRICE	RCNLD	PHOTO
								06/09/2023

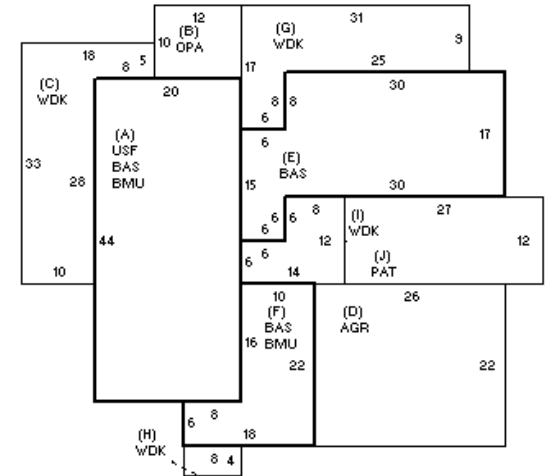
BUILDING

BUILDING	CD	ADJ	DESC	MEASURE	8/11/2015	FC
MODEL	1		RESIDENTIAL	LIST	8/18/2015	FC
STYLE	5	1.05	COLONIAL [100%]	REVIEW	12/15/2010	MR
QUALITY	+	1.15	GOOD-AVE+ [100%]			
FRAME	1	1.00	WOOD FRAME [100%]			

BLDG COMMENTS
 2 FULL & 2 HALF BATHS (1 HALF BATH IN BSMT W/ CONC FLR+NO HEAT). FPL (2-SIDED) & WOODSTOVE ON 1ST FLR & FPL ON 2ND FLR ALL OFF SAME CHIMNEY. Minisplit.

G

YEAR BLT	1980	SIZE ADJ	0.990	ELEMENT	CD	DESCRIPTION	ADJ	S	BAT	T	DESCRIPTION	UNITS	YB	ADJ PRICE	RCN	TOTAL RCN	1,058,805		
NET AREA	2,628	DETAIL ADJ	1.000	FOUNDATION	4	BSMT WALL	1.00	+	BMU	N	BSMT UNFINISHED	1,148		78.56	90,183	CONDITION ELEM	CD		
\$NLA(RCN)	\$403	OVERALL	1.000	EXT. COVER	1	WOOD SHINGLES	1.00	+	BAS	L	BAS AREA	1,148	1980	333.96	383,385				
				ROOF SHAPE	1	GABLE	1.00	A	USF	L	UP-STRY FIN	880	1980	266.70	234,695				
				ROOF COVER	1	ASPHALT SHINGLE	1.00	B	OPA	N	OPEN PORCH	120		88.80	10,656				
				FLOOR COVER	3	W/W CARPET	1.00	+	WDK	N	ATT WOOD DECK	861		51.32	44,185				
				INT. FINISH	2	DRYWALL	1.00	D	AGR	N	ATTACHED GARAGE	572		102.89	58,855				
				HEATING/COOLING	5	ELECTRIC	0.95	E	BAS	L	BAS AREA	600	1990	333.96	200,376				
				FUEL SOURCE	3	ELECTRIC	1.00	J	PAT	N	PATIO	324		16.94	5,488				
								F22	O		FPL 2S 2OP	1		23,981.40	23,981				
CAPACITY		UNITS	ADJ															EFF.YR/AGE	1990 / 32
STORIES(FAR)		2	1.00															COND	30 30 %
ROOMS		6	1.00															FUNC	0
BEDROOMS		3	1.00															ECON	0
BATHROOMS		3	1.00															DEPR	30 % GD 70
FIXTURES		10	\$7,000															RCNLD	\$741,200
UNITS		1	1.00																