

Key: 2653

Town of TRURO - Fiscal Year 2024

9/27/2023 7:11 pm SEQ #: 2.726

LEGAL

CURRENT OWNER				PARCEL ID				LOCATION			
6 NEIGHBOR LANE REALTY TR TRS: JONATHAN H MARK & JESSICA 38 MARES POND DRIVE EAST FALMOUTH, MA 02536				47-78-0				6 NEIGHBOR LN			
TRANSFER HISTORY				DOS	T	SALE PRICE	BK-PG (Cert)				
6 NEIGHBOR LANE REALTY TR				01/06/1997	F		(143237)				

CLASS	CLASS%	DESCRIPTION			BN ID	BN	CARD	
1010	100	SINGLE FAMILY				1	1 of 1	
PMT NO	PMT DT	TY	DESC	AMOUNT	INSP	BY	1st	%
02-141	07/09/2002	6	SHED	5,000	04/11/2003	BT	100	100

LAND

CD	T	AC/SF/UN	Nbhd	Inf1	Inf2	ADJ BASE	SAF	Inf3	Lpi	VC	CREDIT AMT	ADJ VALUE
100	A	0.775	12	1.00	1	1.00	1	1.00	R07	1.30		362,800
300	A	1.105	12	1.00	1	1.00	1	1.00	R07	1.30		39,500

TOTAL	1.880 Acres	ZONING	RES	FRNT	0	ASSESSED	CURRENT	PREVIOUS
Nbhd	EAST TRURO	N O T E	WDK att to SHF			LAND	402,300	269,100
Inf1	NO ADJ		LAND	150,200	127,500			
Inf2	NO ADJ		DETACHED	12,900	12,300			
						OTHER	0	0
						TOTAL	565,400	408,900

DETACHED

TY	QUAL	COND	DIM/NOTE	YB	UNITS	ADJ PRICE	RCNLD
ST1	+	1.10	A 0.75 11*14	2002	154	104.94	12,100
WDK	E	1.80	E 1.00 6*7	2002	42	19.80	800

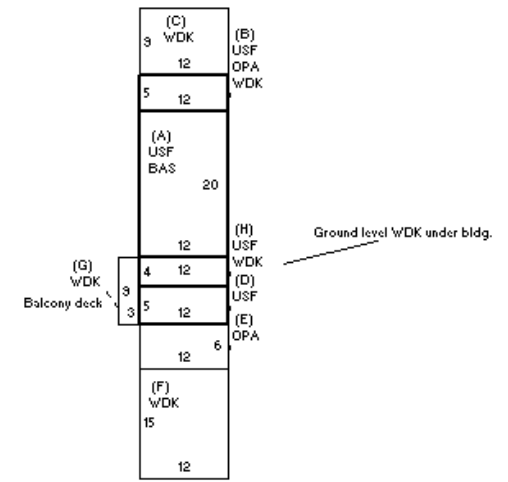

BUILDING

BUILDING	CD	ADJ	DESC	MEASURE	5/24/2018	LG
MODEL	1		RESIDENTIAL	LIST	6/28/2018	LG
STYLE	8	1.10	CONTEMPORARY [100%]	REVIEW	12/15/2010	MR
QUALITY	A	1.00	AVERAGE [100%]			
FRAME	1	1.00	WOOD FRAME [100%]			

BLDG COMMENTS
DWLG JUTS OUT FROM TOP OF EMBANKMENT, no view, no oven, no indoor shower.

G

YEAR BLT	1970	SIZE ADJ	1.060	ELEMENT	CD	DESCRIPTION	ADJ	S	BAT	T	DESCRIPTION	UNITS	YB	ADJ PRICE	RCN	TOTAL RCN	220,941		
NET AREA	648	DETAIL ADJ	1.000	FOUNDATION	1	PIER	1.00	A	BAS	L	BAS AREA	240	1970	331.64	79,593	CONDITION ELEM	CD		
\$NLA(RCN)	\$341	OVERALL	1.030	EXT. COVER	10	VERT. BOARD	1.00	+	WDK	N	ATT WOOD DECK	423		52.49	22,205				
				ROOF SHAPE	4	FLAT/SHED	1.00	+	USF	L	UP-STRY FIN	408	1970	261.03	106,502				
				ROOF COVER	1	ASPHALT SHINGLE	1.00	+	OPA	N	OPEN PORCH	132		85.16	11,241				
				FLOOR COVER	2	SOFTWOOD	1.00		ODS	O	OUT DOOR SHOWER			0.00					
				INT. FINISH	5	OTHER	1.00												
				HEATING/COOLING	13	NO HEAT	0.93												
				FUEL SOURCE	8	NONE	1.00												
																		EFF.YR/AGE	1979 / 43
																		COND	32 32 %
																		FUNC	0
																		ECON	0
																		DEPR	32 % GD 68
																		RCNLD	\$150,200