

Key: 2681

Town of TRURO - Fiscal Year 2024

9/27/2023 7:11 pm SEQ #: 2.756

LEGALS

CURRENT OWNER		PARCEL ID		LOCATION	
RICE LOUISE B & EWING ESTHER H 104 AUBURN ST CAMBRIDGE, MA 02139		47-107-0		3 HUCKLEBERRY LN	
TRANSFER HISTORY		DOS	T	SALE PRICE	BK-PG (Cert)
RICE LOUISE B & EWING EST		09/20/2002	99		15621-65
RICE LOUISE B &		03/08/1996	QS	164,500	10093-164

CLASS	CLASS%	DESCRIPTION			BN ID	BN	CARD	
1010	100	SINGLE FAMILY				1	1 of 1	
PMT NO	PMT DT	TY	DESC	AMOUNT	INSP	BY	1st	%
21-119	04/05/2021	80	SOLAR TAXABL	15,690	08/27/2021	LG	100	100
97-061	05/01/1997	1	SINGLE FAM R	210,000	08/01/1998		100	100

LAND

CD	T	AC/SF/UN	Nbhd	Inf1	Inf2	ADJ BASE	SAF	Inf3	Lpi	VC	CREDIT AMT	ADJ VALUE
100	A	0.775	12	1.00	1	1.00	1	1.00	R07	1.30		362,800
300	A	1.075	12	1.00	1	1.00	1	1.00	R07	1.30		38,430

TOTAL	1.850 Acres	ZONING	RES	FRNT	0	ASSESSED	CURRENT	PREVIOUS
Nbhd	EAST TRURO	NOTE	LAND	401,200	348,900	BUILDING	607,400	499,600
Inf1	NO ADJ		DETACHED	0	0	OTHER	0	0
Inf2	NO ADJ		TOTAL	1,008,600	848,500			

DETACHED

TY	QUAL	COND	DIM/NOTE	YB	UNITS	ADJ PRICE	RCNLD

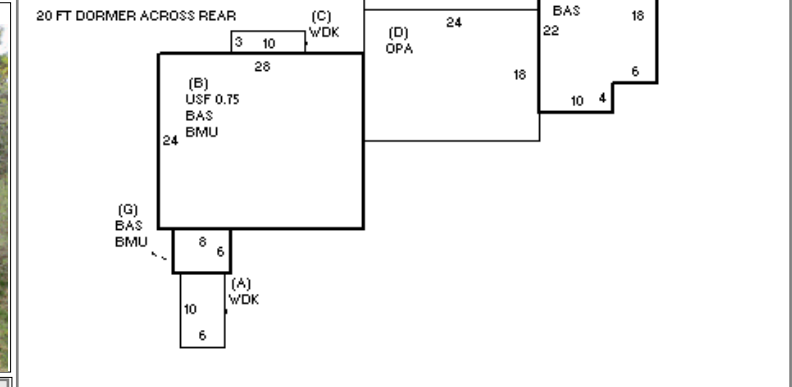

BUILDING

BUILDING	CD	ADJ	DESC	MEASURE	5/27/2016	FC
MODEL	1		RESIDENTIAL	LIST	5/27/2016	FC
STYLE	4	1.10	CAPE [100%]	REVIEW	12/15/2010	MR
QUALITY	+	1.15	GOOD-AVE+ [100%]			
FRAME	1	1.00	WOOD FRAME [100%]			

BLDG COMMENTS

LOADING

YEAR BLT	1997	SIZE ADJ	1.010	ELEMENT	CD	DESCRIPTION	ADJ	S	BAT	T	DESCRIPTION	UNITS	YB	ADJ PRICE	RCN	TOTAL RCN	809,905
NET AREA	1,847	DETAIL ADJ	1.000	FOUNDATION	4	BSMT WALL	1.00	+	WDK	N	ATT WOOD DECK	378		66.46	25,120	CONDITION ELEM	CD
\$NLA(RCN)	\$439	OVERALL	1.120	EXT. COVER	1	WOOD SHINGLES	1.00	+	BMU	N	BSMT UNFINISHED	720		99.05	71,313		
CAPACITY		UNITS	ADJ	ROOF SHAPE	1	GABLE	1.00	+	USF	L	UP-STRY FIN	799	1997	307.88	245,995		
STORIES(FAR)	2	1.00		ROOF COVER	1	ASPHALT SHINGLE	1.00	D	OPA	N	OPEN PORCH	432		81.18	35,068		
ROOMS	0	1.00		FLOOR COVER	2	SOFTWOOD	1.00	+	BAS	L	BAS AREA	1,048	1997	395.15	414,117		
BEDROOMS	3	1.00		INT. FINISH	2	DRYWALL	1.00	F11	O	FPL 1S 1OP	1		14,092.40	14,092			
BATHROOMS	2	1.00		HEATING/COOLING	2	HOT WATER	1.02										
FIXTURES	6	\$4,200		FUEL SOURCE	1	OIL	1.00										
UNITS	0	1.00															
																EFF.YR/AGE	1997 / 25
																COND	25 25%
																FUNC	0
																ECON	0
																DEPR	25 % GD 75
																RCNLD	\$607,400