

Key: 2762

Town of TRURO - Fiscal Year 2024

9/27/2023 7:11 pm SEQ #: 2.847

LEGALS

LAND

DETACHED

BUILDING

CURRENT OWNER				PARCEL ID				LOCATION			
TOMS HILL PROPERTIES LLC MGR: SUSAN H ARESON PO BOX 65 TRURO, MA 02666				49-10-0				39 TOMS HILL RD			
TRANSFER HISTORY				DOS	T	SALE PRICE	BK-PG (Cert)				
TOMS HILL PROPERTIES LLC				01/02/2019	F	1	31760-37				
ARESON, NANCY, DAVID ET A				01/02/2019	F	1	31760-37				
RALA INC &				11/12/1999	99		8972-308+				

CD	T	AC/SF/UN	Nbhd	Infl1	Infl2	ADJ BASE	SAF	Infl3	Lpi	VC	CREDIT AMT	ADJ VALUE
100	A	0.640	13	1.00	1	1.00	1	1.00	V17	4.70		1,236,340

TOTAL	27,878 SF	ZONING	RES	FRNT	0	ASSESSED	CURRENT	PREVIOUS
Nbhd	CORN HILL	N O T E	PL493-98=P/O"ARESON"LOT+ROW IN BK4615/348. IS NOT WF BUT ON BLUFF W/PANORAMIC VIEW OVER CONSERV, RIVER+MARSH LAND.			LAND	1,236,300	1,075,000
Infl1	NO ADJ		BUILDING	683,600	561,200			
Infl2	NO ADJ		DETACHED	500	500			
						OTHER	200,900	165,200
						TOTAL	2,121,300	1,801,900

TY	QUAL	COND	DIM/NOTE	YB	UNITS	ADJ PRICE	RCNLD
SHF	A	1.00	A 0.75 6*7		42	17.17	500



BLDG COMMENTS		

BUILDING	CD	ADJ	DESC	MEASURE	2/17/2022	LG
MODEL	1		RESIDENTIAL	LIST	2/17/2022	LG
STYLE	8	1.10	CONTEMPORARY [100%]	REVIEW	6/1/2011	MR
QUALITY	+	1.15	GOOD-AVE+ [100%]			
FRAME	1	1.00	WOOD FRAME [100%]			

CLASS	CLASS%	DESCRIPTION			BN ID	BN	CARD	
1010	100	SINGLE FAMILY				1	1 of 2	
PMT NO	PMT DT	TY	DESC	AMOUNT	INSP	BY	1st	%
08-088	05/09/2008	40	STUDIO		11/09/2012	FC	100	100
08-085	05/06/2008	1	SINGLE FAM R	650,000	11/09/2012	FC	100	100
	05/13/2006	30	CHECK DATA		05/16/2007	JH	100	100
		30	CHECK DATA		09/30/2002	BT	100	100
93-026	03/13/1993	2	ADDITION	10,000	06/07/1993		100	100

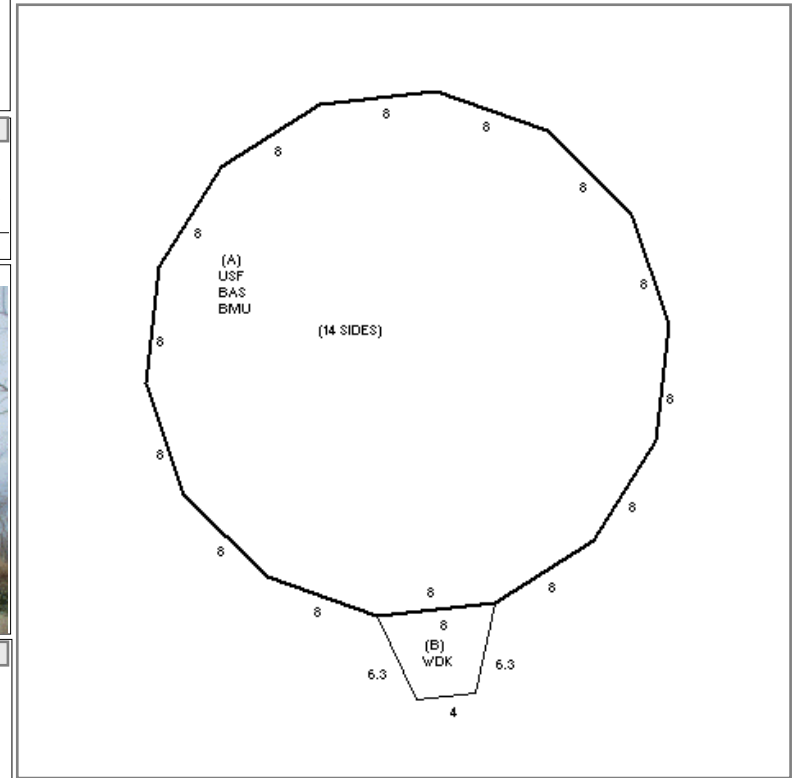

YEAR BLT	2009	SIZE ADJ	1.010
NET AREA	1,962	DETAIL ADJ	1.000
\$NLA(RCN)	\$400	OVERALL	1.030
CAPACITY		UNITS	ADJ
STORIES(FAR)	2	1.00	
ROOMS	7	1.00	
BEDROOMS	3	1.00	
BATHROOMS	2	1.00	
FIXTURES	6	\$4,200	
UNITS	0	1.00	

ELEMENT	CD	DESCRIPTION	ADJ	S	BAT	T	DESCRIPTION	UNITS	YB	ADJ PRICE	RCN
FOUNDATION	4	BSMT WALL	1.00	A	BMU	N	BSMT UNFINISHED	981		86.26	84,618
EXT. COVER	1	WOOD SHINGLES	1.00	A	BAS	L	BAS AREA	981	2009	363.40	356,493
ROOF SHAPE	7	OTHER	1.00	A	USF	L	UP-STRY FIN	981	2009	280.25	274,925
ROOF COVER	1	ASPHALT SHINGLE	1.00	B	WDK	N	ATT WOOD DECK	36		104.25	3,753
FLOOR COVER	1	HARDWOOD	1.00	WDK	N	ATT WOOD DECK	360		61.12	22,002	
INT. FINISH	2	DRYWALL	1.00	WDK	N	ATT WOOD DECK	225		64.71	14,560	
HEATING/COOLING	13	NO HEAT	0.93	F22	O	FPL 2S 2OP	1		25,199.80	25,200	
FUEL SOURCE	8	NONE	1.00	ODS	O	OUT DOOR SHOWER	1		0.00		

TOTAL RCN	785,750
CONDITION ELEM	CD
EFF.YR/AGE	2009 / 13
COND	13 13 %
FUNC	0
ECON	0
DEPR	13 % GD 87
RCNLD	\$683,600

Key: 2762

Town of TRURO - Fiscal Year 2024

9/27/2023 7:11 pm SEQ #: 2.848

LEGAL

CURRENT OWNER		PARCEL ID		LOCATION	
TOMS HILL PROPERTIES LLC		49-10-0		39 TOMS HILL RD	
MGR: SUSAN H ARESON		TRANSFER HISTORY		DOS	T
PO BOX 65				SALE PRICE	BK-PG (Cert)
TRURO, MA 02666					

CLASS	CLASS%	DESCRIPTION			BN ID	BN	CARD	
1010	100	SINGLE FAMILY				2	2 of 2	
PMT NO	PMT DT	TY	DESC	AMOUNT	INSP	BY	1st	%

LAND

CD	T	AC/SF/UN	Nbhd	Infl1	Infl2	ADJ BASE	SAF	Infl3	Lpi	VC	CREDIT AMT	ADJ VALUE

TOTAL	ZONING	FRNT	ASSESSED	CURRENT	PREVIOUS
Nbhd	NOTE		LAND	200,900	
Infl1		BUILDING			
Infl2		DETACHED			
			OTHER		
			TOTAL		

DETACHED

TY	QUAL	COND	DIM/NOTE	YB	UNITS	ADJ PRICE	RCNLD

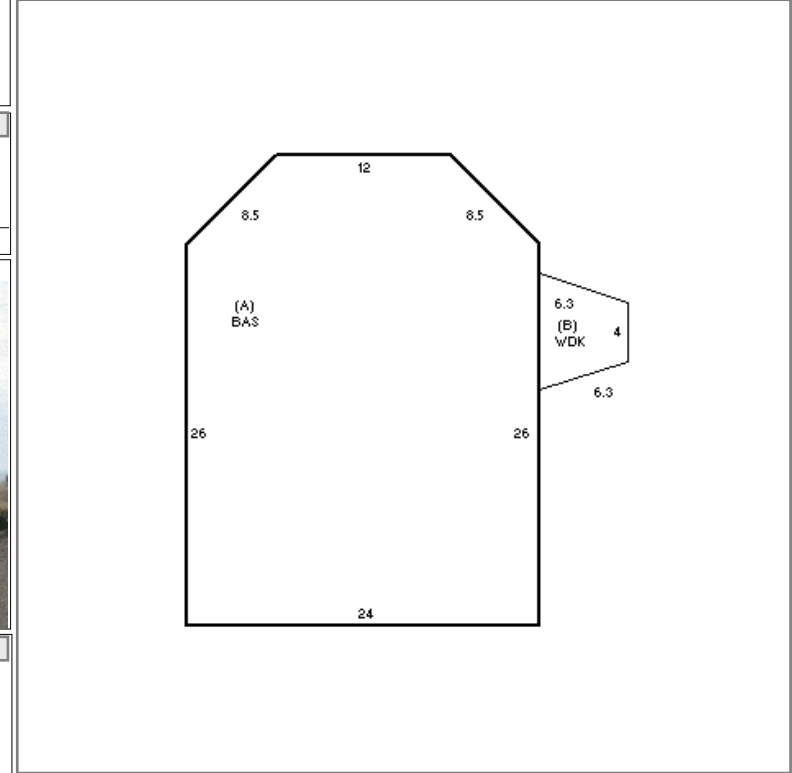

BUILDING

BUILDING	CD	ADJ	DESC	MEASURE	2/17/2022	LG
MODEL	1		RESIDENTIAL	LIST	2/17/2022	LG
STYLE	14	0.90	DET BLDG [100%]	REVIEW	12/3/2010	MR
QUALITY	+	1.15	GOOD-AVE+ [100%]			
FRAME	1	1.00	WOOD FRAME [100%]			

BLDG COMMENTS
No oven/stove, no BMU per 2022 List.

G

YEAR BLT	2009	SIZE ADJ	1.060	ELEMENT	CD	DESCRIPTION	ADJ	S	BAT	T	DESCRIPTION	UNITS	YB	ADJ PRICE	RCN	TOTAL RCN	230,940
NET AREA	732	DETAIL ADJ	1.000	FOUNDATION	4	BSMT WALL	1.00	A	BAS	L	BAS AREA	732	2009	307.33	224,966	CONDITION ELEM	CD
\$NLA(RCN)	\$315	OVERALL	0.830	EXT. COVER	1	WOOD SHINGLES	1.00	B	WDK	N	ATT WOOD DECK	36		88.16	3,174		
CAPACITY		UNITS	ADJ	ROOF SHAPE	1	GABLE	1.00										
STORIES(FAR)		1	1.00	ROOF COVER	1	ASPHALT SHINGLE	1.00										
ROOMS		3	1.00	FLOOR COVER	1	HARDWOOD	1.00										
BEDROOMS		2	1.00	INT. FINISH	2	DRYWALL	1.00										
BATHROOMS		1	1.00	HEATING/COOLING	13	NO HEAT	0.93										
FIXTURES		4	\$2,800	FUEL SOURCE	8	NONE	1.00										
UNITS		0	1.00														
																EFF.YR/AGE	2009 / 13
																COND	13 13 %
																FUNC	0
																ECON	0
																DEPR	13 % GD 87
																RCNLD	\$200,900