

Key: 2842

Town of TRURO - Fiscal Year 2024

9/27/2023 7:11 pm SEQ #: 2.930

LEGAL

LAND

DETACHED

BUILDING

CURRENT OWNER		PARCEL ID		LOCATION	
MCGIRR KEVIN 129 WILLOUGHBY AVENUE BROOKLYN, NY 11205		50-58-0		13 MEETINGHOUSE RD	
TRANSFER HISTORY		DOS	T	SALE PRICE	BK-PG (Cert)
MCGIRR KEVIN		01/30/2015	QS	610,000	28656-312
MURRAY KRISTIN A		11/05/1999	QS	143,000	12650-114+

CLASS	CLASS%	DESCRIPTION		BN ID	BN	CARD	
1010	100	SINGLE FAMILY			1	1 of 1	
PMT NO	PMT DT	TY	DESC	AMOUNT	INSP	BY	1st %
19-339X	10/22/2019	90	BP NVC	1,300	01/22/2020	LG	100 100
16-065	04/07/2016	2	ADDITION	42,000	03/17/2017	LG	100 100
00-170	11/01/2000	1	SINGLE FAM R	185,000	03/31/2002	BT	100 100

CD	T	AC/SF/UN	Nbhd	Inf1	Inf2	ADJ BASE	SAF	Inf3	Lpi	VC	CREDIT AMT	ADJ VALUE
100	A	0.775 14	1.00 1	1.00 1	1.00	468,130	1.00 1	1.00 R05	1.30			362,800
300	A	0.005 14	1.00 1	1.00 1	1.00	35,750	1.00 1	1.00 R05	1.30			180

TOTAL	33,977 SF	ZONING	RES	FRNT	0	ASSESSED	CURRENT	PREVIOUS
Nbhd	TRURO CENTER	NOTE			LAND	363,000	279,200	
Inf1	NO ADJ		BUILDING	767,300	635,000			
Inf2	NO ADJ		DETACHED	1,000	900			
			OTHER	0	0			
TOTAL						1,131,300	915,100	

TY	QUAL	COND	DIM/NOTE	YB	UNITS	ADJ PRICE	RCNLD
SHF	A	1.00 A	0.75 8*10	2001	80	16.47	1,000

PHOTO 02/23/2021

BLDG COMMENTS

3/29/2021 Owner confirmed interior data via email (C-19).

PER 5/11 LIST: CATH CLG IN 13X28+12X8 SECTIONS
EPA HAS CARPETED FLR+CLG FAN+TONGUE/GROOVE WALLS+CLG

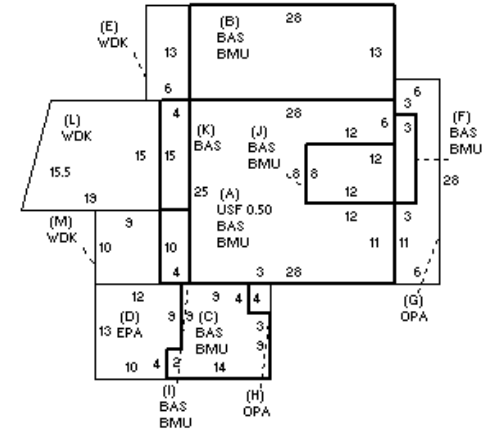

BUILDING	CD	ADJ	DESC	MEASURE	2/23/2021	LG
MODEL	1		RESIDENTIAL	LIST	3/29/2021	LG
STYLE	4	1.10	CAPE [100%]	REVIEW	11/29/2010	MR
QUALITY	G	1.35	GOOD [100%]			
FRAME	1	1.00	WOOD FRAME [100%]			

YEAR BLT	2001	SIZE ADJ	1.020	ELEMENT	CD	DESCRIPTION	ADJ	S	BAT	T	DESCRIPTION	UNITS	YB	ADJ PRICE	RCN	TOTAL RCN	971,258
NET AREA	1,654	DETAIL ADJ	1.000	FOUNDATION	4	BSMT WALL	1.00	+	BAS	N	BSMT UNFINISHED	1,292		102.41	132,315	CONDITION ELEM	CD
\$NLA(RCN)	\$587	OVERALL	1.120	EXT. COVER	1	WOOD SHINGLES	1.00	+	BAS	L	BAS AREA	1,196	2001	463.87	554,790		
CAPACITY				ROOF SHAPE	1	GABLE	1.00	A	USF	L	UP-STRY FIN	302	2001	370.59	111,917		
STORIES(FAR)	1.65	1.00	ROOF COVER	1	ASPHALT SHINGLE	1.00	D	EPA	N	ENCL PORCH	148		213.91	31,659			
ROOMS	6	1.00	FLOOR COVER	2	SOFTWOOD	1.00	+	WDK	N	ATT WOOD DECK	423		74.15	31,366			
BEDROOMS	3	1.00	INT. FINISH	2	DRYWALL	1.00	+	OPA	N	OPEN PORCH	144		120.29	17,322			
BATHROOMS	2.5	1.00	HEATING/COOLING	2	HOT WATER	1.02	J	BAS	L	BAS AREA	96	2001	463.88	44,532			
FIXTURES	8	\$5,600	FUEL SOURCE	2	GAS	1.00	K	BAS	L	BAS AREA	60	2016	463.88	27,833			
UNITS	1	1.00						GFP	O	GAS FIREPLACE	1		13,923.30	13,923			
								ODS	O	OUT DOOR SHOWER			0.00				
EFF.YR/AGE 2001 / 21																	
COND 21 21 %																	
FUNC 0																	
ECON 0																	
DEPR 21 % GD 79																	
RCNLD \$767,300																	