

Key: 2857

Town of TRURO - Fiscal Year 2024

9/27/2023 7:11 pm SEQ #: 2.948

LEGAL

LAND

DETACHED

BUILDING

| CURRENT OWNER | | | | PARCEL ID | | | | LOCATION | | | | |
|----------------------------|--|--|--|---------------------|--|--|--|------------------|----|------------|--------------|--|
| WHAEAL REALTY TRUST | | | | 50-74-0 | | | | 6 CASTLE HILL LN | | | | |
| TRS: JALKUT THOMAS P ET AL | | | | TRANSFER HISTORY | | | | DOS | T | SALE PRICE | BK-PG (Cert) | |
| 155 SEAPORT BLVD | | | | WHAEAL REALTY TRUST | | | | 07/20/2009 | 99 | 17791-95+ | | |
| BOSTON, MA 02210-2604 | | | | WHAEAL REALTY TRUST | | | | 10/14/2003 | QS | 1,600,000 | 17791-95 | |
| | | | | REICHHHELM CAROLE D | | | | 07/07/2000 | QS | 750,000 | 13116-284 | |

| CLASS | CLASS% | DESCRIPTION | | | BN ID | BN | CARD | |
|--------|------------|---------------|---------------|--------|------------|----|--------|-----|
| 1090 | 100 | MULTIPLE HSES | | | | 1 | 1 of 2 | |
| PMT NO | PMT DT | TY | DESC | AMOUNT | INSP | BY | 1st | % |
| 94-118 | 09/14/1994 | 2 | ADDITION | 20,000 | 06/26/1995 | | 100 | 100 |
| 89-157 | 10/23/1989 | 3 | REPAIR/REMODO | 5,000 | 12/31/1989 | | 100 | 100 |

| CD | T | AC/SF/UN | Nbhd | Infl1 | Infl2 | ADJ BASE | SAF | Infl3 | Lpi | VC | CREDIT AMT | ADJ VALUE |
|-----|---|----------|------|-------|-------|-----------|------|-------|------|-----|------------|-----------|
| 100 | A | 0.775 | 13 | 1.00 | 1 | 1,548,430 | 1.00 | 1 | 1.00 | RF3 | 4.30 | 1,200,030 |
| 300 | A | 0.275 | 13 | 1.00 | 1 | 118,250 | 1.00 | 1 | 1.00 | RF3 | 4.30 | 32,520 |

| TOTAL | 1.050 Acres | ZONING | RES | FRNT | 173 | ASSESSED | CURRENT | PREVIOUS |
|-------|-------------|--------|-----|------|-----|--------------|------------------|------------------|
| Nbhd | CORN HILL | NOTE | | | | LAND | 1,232,600 | 1,071,700 |
| Infl1 | NO ADJ | | | | | BUILDING | 735,200 | 597,200 |
| Infl2 | NO ADJ | | | | | DETACHED | 1,200 | 1,100 |
| | | | | | | OTHER | 392,600 | 337,900 |
| | | | | | | TOTAL | 2,361,600 | 2,007,900 |

| TY | QUAL | COND | DIM/NOTE | YB | UNITS | ADJ PRICE | RCNLD |
|-----|------|------|-------------|----|-------|-----------|-------|
| SHF | A | 1.00 | A 0.75 8*12 | | 96 | 16.47 | 1,200 |



BLDG COMMENTS
 NOTE: Bldg 1 is the farther bldg on the lot. 6/21/2022
 Owner confirmed/corrected interior information at door (C-19).

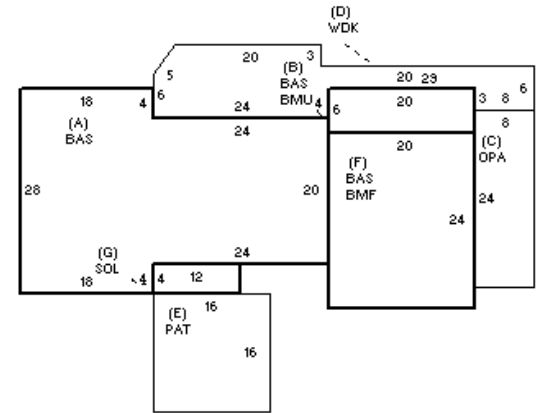

| BUILDING | CD | ADJ | DESC | MEASURE | 6/21/2022 | LG |
|----------|----|------|-------------------|---------|------------|----|
| MODEL | 1 | | RESIDENTIAL | LIST | 6/21/2022 | LG |
| STYLE | 1 | 1.00 | RANCH [100%] | REVIEW | 12/16/2010 | MR |
| QUALITY | + | 1.15 | GOOD-AVE+ [100%] | | | |
| FRAME | 1 | 1.00 | WOOD FRAME [100%] | | | |

| YEAR BLT | 1966 | SIZE ADJ | 1.020 | ELEMENT | CD | DESCRIPTION | ADJ | S | BAT | T | DESCRIPTION | UNITS | YB | ADJ PRICE | RCN | TOTAL RCN | 735,224 |
|--------------|-------|------------|-------|-----------------|----|-----------------|------|-----|-----|---|-----------------|-------|------|-----------|---------|----------------|---------|
| NET AREA | 1,632 | DETAIL ADJ | 1.000 | FOUNDATION | 4 | BSMT WALL | 1.00 | + | BAS | L | BAS AREA | 1,584 | 1966 | 356.31 | 564,388 | CONDITION ELEM | CD |
| \$NLA(RCN) | \$451 | OVERALL | 1.020 | EXT. COVER | 1 | WOOD SHINGLES | 1.00 | B | BMU | N | BSMT UNFINISHED | 120 | | 97.74 | 11,729 | | |
| CAPACITY | | | | ROOF SHAPE | 1 | GABLE | 1.00 | C | OPA | N | OPEN PORCH | 192 | | 88.66 | 17,022 | | |
| STORIES(FAR) | 1 | 1.00 | | ROOF COVER | 1 | ASPHALT SHINGLE | 1.00 | D | WDK | N | ATT WOOD DECK | 339 | | 61.12 | 20,720 | | |
| ROOMS | 0 | 1.00 | | FLOOR COVER | 1 | HARDWOOD | 1.00 | E | PAT | N | PATIO | 256 | | 18.84 | 4,824 | | |
| BEDROOMS | 2 | 1.00 | | INT. FINISH | 2 | DRYWALL | 1.00 | F | BMF | N | BSMT FINISH | 480 | | 170.94 | 82,051 | | |
| BATHROOMS | 3 | 1.00 | | HEATING/COOLING | 2 | HOT WATER | 1.02 | G | SOL | L | SOLARIUM | 48 | 1966 | 212.25 | 10,188 | | |
| BATHROOMS | 3 | 1.00 | | FUEL SOURCE | 1 | OIL | 1.00 | F12 | O | | FPL 1S 2OP | 1 | | 18,001.90 | 18,002 | | |
| FIXTURES | 9 | \$6,300 | | | | | | ODS | O | | OUT DOOR SHOWER | 1 | | 0.00 | | | |
| UNITS | 0 | 1.00 | | | | | | | | | | | | | | | |
| EFF.YR/AGE | | | | | | | | | | | | | | | | 0 / 0 | |
| COND | | | | | | | | | | | | | | | | 0 0 % | |
| FUNC | | | | | | | | | | | | | | | | 0 | |
| ECON | | | | | | | | | | | | | | | | 0 | |
| DEPR | | | | | | | | | | | | | | | | 0 % GD 100 | |
| RCNLD | | | | | | | | | | | | | | | | \$735,200 | |

Key: 2857

Town of TRURO - Fiscal Year 2024

9/27/2023 7:11 pm SEQ #: 2.949

LEGAL

| | | | | | | | | | | | |
|----------------------------|--|--|--|------------------|--|--|--|------------------|---|------------|--------------|
| CURRENT OWNER | | | | PARCEL ID | | | | LOCATION | | | |
| WHAEL REALTY TRUST | | | | 50-74-0 | | | | 6 CASTLE HILL LN | | | |
| TRS: JALKUT THOMAS P ET AL | | | | TRANSFER HISTORY | | | | DOS | T | SALE PRICE | BK-PG (Cert) |
| 155 SEAPORT BLVD | | | | | | | | | | | |
| BOSTON, MA 02210-2604 | | | | | | | | | | | |

| CLASS | CLASS% | DESCRIPTION | | | BN ID | BN | CARD | |
|--------|--------|---------------|------|--------|-------|----|--------|---|
| 1090 | 100 | MULTIPLE HSES | | | | 2 | 2 of 2 | |
| PMT NO | PMT DT | TY | DESC | AMOUNT | INSP | BY | 1st | % |
| | | | | | | | | |

LAND

| CD | T | AC/SF/UN | Nbhd | Inf1 | Inf2 | ADJ BASE | SAF | Inf3 | Lpi | VC | CREDIT AMT | ADJ VALUE |
|----|---|----------|------|------|------|----------|-----|------|-----|----|------------|-----------|
| | | | | | | | | | | | | |

| TOTAL | ZONING | FRNT | ASSESSED | CURRENT | PREVIOUS |
|-------|--------|----------|----------|---------|----------|
| Nbhd | NOTE | | LAND | 392,600 | |
| Inf1 | | BUILDING | | | |
| Inf2 | | DETACHED | | | |
| | | | OTHER | | |
| | | | TOTAL | | |

DETACHED

| TY | QUAL | COND | DIM/NOTE | YB | UNITS | ADJ PRICE | RCNLD |
|----|------|------|----------|----|-------|-----------|-------|
| | | | | | | | |

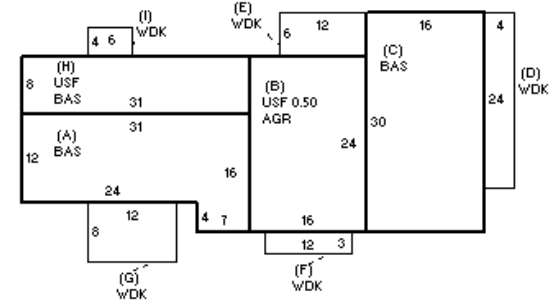

BUILDING

| BUILDING | CD | ADJ | DESC | MEASURE | 6/21/2022 | LG |
|----------|----|------|-------------------|---------|------------|----|
| MODEL | 1 | | RESIDENTIAL | LIST | 6/21/2022 | LG |
| STYLE | 4 | 1.10 | CAPE [100%] | REVIEW | 12/16/2010 | MR |
| QUALITY | A | 1.00 | AVERAGE [100%] | | | |
| FRAME | 1 | 1.00 | WOOD FRAME [100%] | | | |

BLDG COMMENTS
 6/21/2022 Owner confirmed interior data at door (C-19).
 Former wood workshop/gallery. USF=BA & Kitchen.

G

| YEAR BLT | 1994 | SIZE ADJ | 1.020 | ELEMENT | CD | DESCRIPTION | ADJ | S | BAT | T | DESCRIPTION | UNITS | YB | ADJ PRICE | RCN | TOTAL RCN | 545,327 |
|--------------|-------|------------|-------|-----------------|----|-----------------|------|---|-----|---|-----------------|-------|------|-----------|---------|----------------|------------|
| NET AREA | 1,568 | DETAIL ADJ | 1.000 | FOUNDATION | 2 | SLAB | 0.95 | + | BAS | L | BAS AREA | 1,128 | 1994 | 325.32 | 366,964 | CONDITION ELEM | CD |
| \$NLA(RCN) | \$348 | OVERALL | 1.050 | EXT. COVER | 1 | WOOD SHINGLES | 1.00 | B | AGR | N | ATTACHED GARAGE | 384 | | 105.59 | 40,547 | | |
| CAPACITY | | UNITS | ADJ | ROOF SHAPE | 1 | GABLE | 1.00 | + | USF | L | UP-STRY FIN | 440 | 1994 | 256.06 | 112,666 | | |
| STORIES(FAR) | 1.5 | 1.00 | | ROOF COVER | 1 | ASPHALT SHINGLE | 1.00 | + | WDK | N | ATT WOOD DECK | 324 | | 54.71 | 17,727 | | |
| ROOMS | 0 | 1.00 | | FLOOR COVER | 2 | SOFTWOOD | 1.00 | | MST | O | MASONRY STACK | 1 | | 3,222.60 | 3,223 | | |
| BEDROOMS | 2 | 1.00 | | INT. FINISH | 2 | DRYWALL | 1.00 | | ODS | O | OUT DOOR SHOWER | 1 | | 0.00 | | | |
| BATHROOMS | 2 | 1.00 | | HEATING/COOLING | 1 | FORCED AIR | 1.00 | | | | | | | | | | |
| FIXTURES | 6 | \$4,200 | | FUEL SOURCE | 1 | OIL | 1.00 | | | | | | | | | | |
| UNITS | 0 | 1.00 | | | | | | | | | | | | | | | |
| | | | | | | | | | | | | | | | | EFF.YR/AGE | 1994 / 28 |
| | | | | | | | | | | | | | | | | COND | 28 28 % |
| | | | | | | | | | | | | | | | | FUNC | 0 |
| | | | | | | | | | | | | | | | | ECON | 0 |
| | | | | | | | | | | | | | | | | DEPR | 28 % GD 72 |
| | | | | | | | | | | | | | | | | RCNLD | \$392,600 |