

Key: 2946

Town of TRURO - Fiscal Year 2024

9/27/2023 7:11 pm SEQ #: 3.058

LEGAL

LAND

DETACHED

BUILDING

CURRENT OWNER				PARCEL ID				LOCATION				
SANDERS ERNEST D II & SANDERS CHRISTINE R 1317 SEATON LN FALLS CHURCH, VA 22046				50-167-0				13 DEPOT RD				
TRANSFER HISTORY				DOS	T	SALE PRICE	BK-PG (Cert)					
SANDERS ERNEST D II & ULLMARK MARILYN PEDALINO-				09/23/2005	QS	842,425	(178028)					
				02/06/1995	QS	280,000	(136325)					

CLASS	CLASS%	DESCRIPTION			BN ID	BN	CARD	
1010	100	SINGLE FAMILY				1	1 of 1	
PMT NO	PMT DT	TY	DESC	AMOUNT	INSP	BY	1st	%
22-310X	08/02/2022	6	SHED		11/09/2022	LG	100	100
97-078	06/01/1997	30	CHECK DATA	20,000	11/01/2005	FC	100	100
87-009	01/23/1987	2	ADDITION	75,000	04/01/1998	SW	100	100
		2	ADDITION		12/31/1987		100	100

CD	T	AC/SF/UN	Nbhd	Inf1	Inf2	ADJ BASE	SAF	Inf3	Lpi	VC	CREDIT AMT	ADJ VALUE
100	A	0.775	15	1.00	1	1.00	1	1.00	RV4	2.30		641,880
300	A	0.655	15	1.00	1	1.00	1	1.00	RV4	2.30		41,430

TOTAL	1.430 Acres	ZONING	RES	FRNT	0	ASSESSED	CURRENT	PREVIOUS
Nbhd	SOUTH TRURO	NOTE				LAND	683,300	516,600
Inf1	NO ADJ		BUILDING	606,600	499,800			
Inf2	NO ADJ		DETACHED	3,100	0			
			OTHER	0	0			
						TOTAL	1,293,000	1,016,400

TY	QUAL	COND	DIM/NOTE	YB	UNITS	ADJ PRICE	RCNLD
SHF	V	1.50	E 1.00 8*16	2022	128	24.01	3,100



BLDG COMMENTS

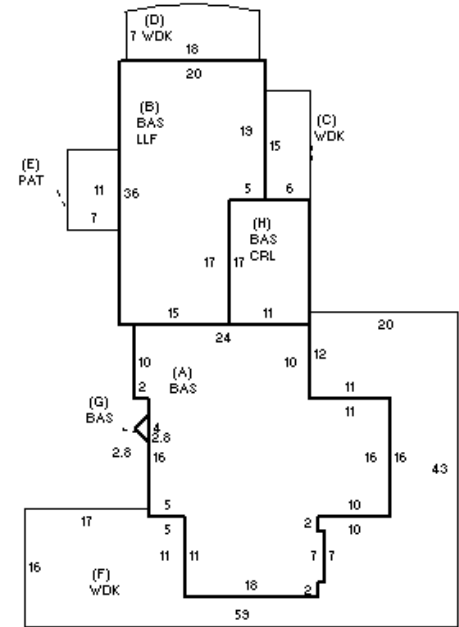

BUILDING	CD	ADJ	DESC	MEASURE	3/2/2022	LG
MODEL	1		RESIDENTIAL	LIST	5/24/2022	LG
STYLE	1	1.00	RANCH [100%]	REVIEW	4/5/2021	MR
QUALITY	+	1.15	GOOD-AVE+ [100%]			
FRAME	1	1.00	WOOD FRAME [100%]			

YEAR BLT	1955	SIZE ADJ	0.995	ELEMENT	CD	DESCRIPTION	ADJ	S	BAT	T	DESCRIPTION	UNITS	YB	ADJ PRICE	RCN	TOTAL RCN	879,201		
NET AREA	2,434	DETAIL ADJ	1.000	FOUNDATION	4	BSMT WALL	1.00	+	BAS	L	BAS AREA	1,799	1955	342.36	615,904	CONDITION ELEM	CD		
\$NLA(RCN)	\$361	OVERALL	1.020	EXT. COVER	2	CLAPBOARD	1.00	B	LLF	L	LOWER LEVEL FIN	635	1955	238.40	151,384				
				ROOF SHAPE	4	FLAT/SHED	1.00	+	WDK	N	ATT WOOD DECK	1,309		52.61	68,865				
				ROOF COVER	7	ROLL	1.00	E	PAT	N	PATIO	77		23.49	1,809				
				FLOOR COVER	1	HARDWOOD	1.00	H	CRL	N	CRAWL SPACE	187		47.87	8,952				
				INT. FINISH	2	DRYWALL	1.00	F11	O	O	FPL 1S 1OP	2		12,643.55	25,287				
				HEATING/COOLING	2	HOT WATER	1.02	ODS	O	O	OUT DOOR SHOWER	1		0.00					
				FUEL SOURCE	1	OIL	1.00												
																		EFF.YR/AGE	1987 / 35
																		COND	31 31 %
																		FUNC	0
																		ECON	0
																		DEPR	31 % GD 69
																		RCNLD	\$606,600