

Key: 2962

Town of TRURO - Fiscal Year 2024

9/27/2023 7:11 pm SEQ #: 3.078

LEGAL

LAND

DETAILED

BUILDING

CURRENT OWNER				PARCEL ID				LOCATION			
OLD BRIDGE ROAD LLC MGR: JAMES M HIRSHBERG 124 VIA VERDE WAY PALM BEACH GARDENS, FL 33418				50-193-0				12 OLD BRIDGE RD			
TRANSFER HISTORY				DOS	T	SALE PRICE	BK-PG (Cert)				
OLD BRIDGE ROAD LLC				12/18/2012	A		26960-35				
HIRSHBERG JAMES M & DIANE				05/15/1986	99		5077-015				

CLASS	CLASS%	DESCRIPTION			BN ID	BN	CARD	
1010	100	SINGLE FAMILY				1	1 of 1	
PMT NO	PMT DT	TY	DESC	AMOUNT	INSP	BY	1st	%
23-320X	08/28/2023	90	BP NVC	602				0
		30	CHECK DATA		04/05/2002	BTT	100	100
97-120	09/01/1997	2	ADDITION	150,000	06/01/1999		100	100
86-099	07/04/1986	1	SINGLE FAM R		12/31/1987	SW	100	100

CD	T	AC/SF/UN	Nbhd	Inf1	Inf2	ADJ BASE	SAF	Inf3	Lpi	VC	CREDIT AMT	ADJ VALUE
100	A	0.775	15	1.00	1	1.00	1	1.00	V9	2.75		767,460
300	A	2.285	15	1.00	1	1.00	1	1.00	V9	2.75		172,800

TOTAL	3.060 Acres	ZONING	RES	FRNT	0	ASSESSED	CURRENT	PREVIOUS
Nbhd	SOUTH TRURO	N O T E	FY11 VW INCR PER FIELD REV= DISTANT PARTIAL OBSTRUCTION.			LAND	940,300	594,500
Inf1	NO ADJ		BUILDING	823,100	681,400			
Inf2	NO ADJ		DETACHED	26,000	24,900			
			OTHER	0	0			
			TOTAL	1,789,400	1,300,800			

TY	QUAL	COND	DIM/NOTE	YB	UNITS	ADJ PRICE	RCNLD
SHF	A	1.00	A 0.75 8X16		128	16.01	1,500
CTA	G	1.18	G 0.90 60X110	1996	1	24,808.67	22,300
SHF	A	1.00	A 0.75 10*14		140	16.01	1,700
WDK	A	1.00	A 0.75 8*8		64	11.00	500

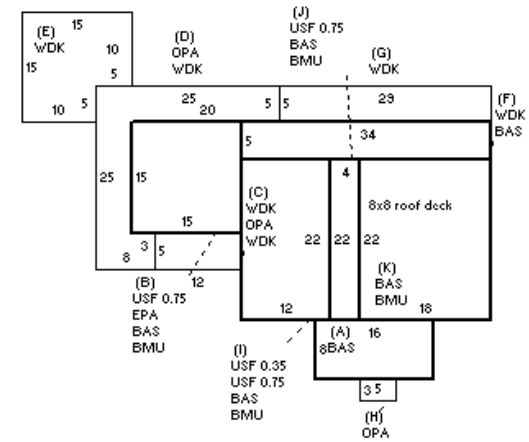

BUILDING	CD	ADJ	DESC	MEASURE	9/11/2019	LG
MODEL	1		RESIDENTIAL	LIST	9/11/2019	LG
STYLE	4	1.10	CAPE [100%]	REVIEW	12/13/2010	MR
QUALITY	G	1.35	GOOD [100%]			
FRAME	1	1.00	WOOD FRAME [100%]			

BLDG COMMENTS
 FY21 HTB deck gone. 97-120 ADDITION W/NEW DKS PICKED UP COMPLT IN 1999 BUT WAS IN AREA 4/02+ PICKED UP CHNGS(8x16 ADDN+ MORE DKS+HTB,ETC) ADDED FY03 (SEE NEW SKETCH)

YEAR BLT	1986	SIZE ADJ	1.010	ELEMENT	CD	DESCRIPTION	ADJ	S	BAT	T	DESCRIPTION	UNITS	YB	ADJ PRICE	RCN	TOTAL RCN	1,055,247
NET AREA	1,796	DETAIL ADJ	1.000	FOUNDATION			1.00	+	BAS	L	BAS AREA	1,271	1986	459.32	583,801		
\$NLA(RCN)	\$588	OVERALL	1.120	EXT. COVER	1	WOOD SHINGLES	1.00	+	BMU	N	BSMT UNFINISHED	973		110.10	107,132		
				ROOF SHAPE	1	GABLE	1.00	B	EPA	N	ENCL PORCH	225		190.63	42,892		
				ROOF COVER	1	ASPHALT SHINGLE	1.00	+	USF	L	UP-STRY FIN	525	1986	365.11	191,684		
				FLOOR COVER	1	HARDWOOD	1.00	+	WDK	N	ATT WOOD DECK	875		68.84	60,231		
				INT. FINISH	2	DRYWALL	1.00	+	OPA	N	OPEN PORCH	315		101.25	31,894		
				HEATING/COOLING	2	HOT WATER	1.02		WDK	N	ATT WOOD DECK	64		119.31	7,636		
				FUEL SOURCE	1	OIL	1.00		F21	O	FPL 2S 1OP	1		22,977.00	22,977		
									ODS	O	OUT DOOR SHOWER			0.00			
																EFF.YR/AGE	2000 / 22
																COND	22 22 %
																FUNC	0
																ECON	0
																DEPR	22 % GD 78
																RCNLD	\$823,100