

Key: 3041

Town of TRURO - Fiscal Year 2024

9/27/2023 7:11 pm SEQ #: 3.159

LEGAL

Table with columns: CURRENT OWNER, PARCEL ID, LOCATION, TRANSFER HISTORY, and various lot details.

Table with columns: CLASS, CLASS%, DESCRIPTION, BN ID, BN, CARD, and payment history.

LAND

Table with columns: TOTAL, ZONING, RES, FRNT, ASSESSED, CURRENT, PREVIOUS.

DETAILED

Table with columns: TY, QUAL, COND, DIM/NOTE, YB, UNITS, ADJ PRICE, RCNLD.

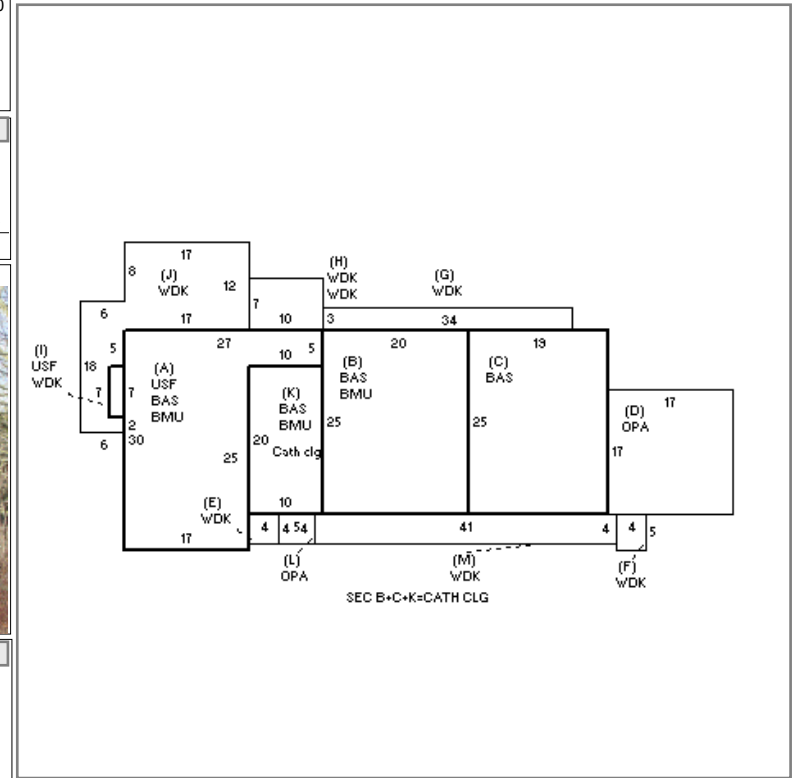

BUILDING

Table with columns: BUILDING, CD, ADJ, DESC, MEASURE, 3/10/2022, LG.

BLDG COMMENTS: 2 METAL CHIMNEYS W/ 1 FPL EACH.

FINANCING

Large summary table with columns: YEAR BLT, SIZE ADJ, ELEMENT, CD, DESCRIPTION, ADJ, S, BAT, T, DESCRIPTION, UNITS, YB, ADJ PRICE, RCN, TOTAL RCN, CONDITION ELEM, CD, EFF. YR/AGE, COND, FUNC, ECON, DEPR, RCNLD.