

Key: 3123

Town of TRURO - Fiscal Year 2024

9/27/2023 7:11 pm SEQ #: 3.244

LEGAL

LAND

DETACHED

BUILDING

INDING

CURRENT OWNER				PARCEL ID				LOCATION			
READ FAMILY NOMINEE TRUST THE TRS: READ BENJAMIN H JR ET AL PO BOX 1929 JACKSON, WY 83001				51-78-0				21 HATCH RD			
TRANSFER HISTORY				DOS	T	SALE PRICE	BK-PG (Cert)				
READ FAMILY NOMINEE TRUST				04/11/2001	99		(161168)				
READ BENJAMIN H JR & MARY				04/10/2001	J	214,333	(161167)				
READ BENJAMIN H JR &				04/09/2001	99		(161166)				

CLASS	CLASS%	DESCRIPTION			BN ID	BN	CARD	
1010	100	SINGLE FAMILY				1	1 of 1	
PMT NO	PMT DT	TY	DESC	AMOUNT	INSP	BY	1st	%
94-105	08/29/1994	4	REHAB	175,000	09/06/1995		100	100

CD	T	AC/SF/UN	Nbhd	Inf1	Inf2	ADJ BASE	SAF	Inf3	Lpi	VC	CREDIT AMT	ADJ VALUE
100	A	0.775	15	1.00	1	1.00	1	1.00	R07	1.45		404,660
300	A	1.235	15	1.00	1	1.00	1	1.00	R07	1.45		49,250

TOTAL	2.010 Acres	ZONING	RES	FRNT	0	ASSESSED	CURRENT	PREVIOUS
Nbhd	SOUTH TRURO	NOTE	LAND	453,900	394,700	BUILDING	633,300	544,900
Inf1	NO ADJ		DETACHED	15,800	15,000	OTHER	0	0
Inf2	NO ADJ		TOTAL	1,103,000	954,600			

TY	QUAL	COND	DIM/NOTE	YB	UNITS	ADJ PRICE	RCNLD
CTA	A	1.00	A 0.75 60*122		1	21,024.30	15,800

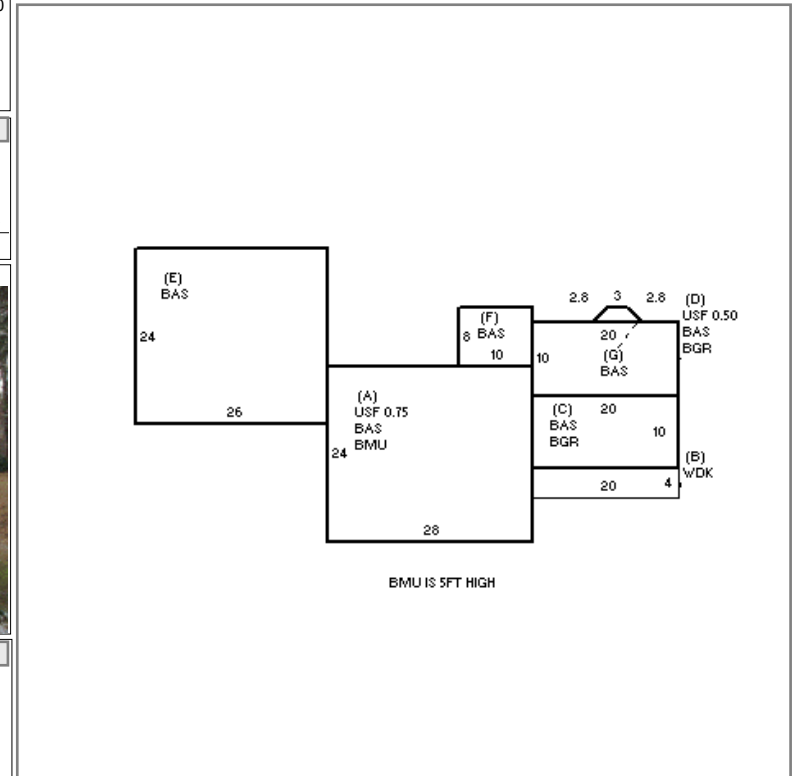

BUILDING	CD	ADJ	DESC	MEASURE	12/4/2019	LG
MODEL	1		RESIDENTIAL	LIST	2/20/2020	LG
STYLE	4	1.10	CAPE [100%]	REVIEW	12/13/2010	MR
QUALITY	A	1.00	AVERAGE [100%]	BLDG COMMENTS		
FRAME	1	1.00	WOOD FRAME [100%]	EYB=COMPLETE REHAB 1994. Sec.A is former South Truro Schoolhouse (moved from orig loc). BMU below accessible only from outside.		

YEAR BLT	1920	SIZE ADJ	0.995	ELEMENT	CD	DESCRIPTION	ADJ	S	BAT	T	DESCRIPTION	UNITS	YB	ADJ PRICE	RCN	TOTAL RCN	879,577
NET AREA	2,390	DETAIL ADJ	1.000	FOUNDATION			1.00	A	BMU	N	BSMT UNFINISHED	672		85.60	57,526	CONDITION ELEM	CD
\$NLA(RCN)	\$368	OVERALL	1.130	EXT. COVER	1	WOOD SHINGLES	1.00	+	USF	L	UP-STRY FIN	604	1920	266.10	160,725		
CAPACITY		UNITS	ADJ	ROOF SHAPE	1	GABLE	1.00	B	WDK	N	ATT WOOD DECK	80		77.71	6,217		
STORIES(FAR)	1.75	1.00		ROOF COVER	1	ASPHALT SHINGLE	1.00	+	BGR	N	SF BSMT GARAGE	400		107.13	42,854		
ROOMS	8	1.00		FLOOR COVER	2	SOFTWOOD	1.00	E	BAS	L	BAS AREA	624	1994	329.81	205,801		
BEDROOMS	5	1.00		INT. FINISH	2	DRYWALL	1.00	+	BAS	L	BAS AREA	1,162	1920	329.81	383,238		
BATHROOMS	2.5	1.00		HEATING/COOLING	9	WARM/COOL AIR	1.03	F21	O	FPL 2S 1OP	1			16,917.00	16,917		
FIXTURES	9	\$6,300		FUEL SOURCE	2	GAS	1.00	ODS	O	OUT DOOR SHOWER	1			0.00			
UNITS	0	1.00															
																EFF.YR/AGE	1994 / 28
																COND	28 28 %
																FUNC	0
																ECON	0
																DEPR	28 % GD 72
																RCNLD	\$633,300