

Key: 3128

Town of TRURO - Fiscal Year 2024

9/27/2023 7:11 pm SEQ #: 3.249

LEGAL

LAND

CURRENT OWNER				PARCEL ID				LOCATION				
RICE JONATHAN E C & RICE JUSTINE MARIA PO BOX 373 NO TRURO, MA 02652-0373				51-83-0				152 RT 6				
				TRANSFER HISTORY				DOS	T	SALE PRICE	BK-PG (Certs)	
				RICE JONATHAN E C & RICE JOHN B RICE NOMINEE TRUST				06/21/2004	A	375,000	(173420+)	
CD	T	AC/SF/UN	Nbhd	Infl1	Infl2	ADJ BASE	SAF	Infl3	Lpi	VC	CREDIT AMT	ADJ VALUE
100	A	0.775 15	1.00	1	1.00	288,080	1.00	1	1.00	R01	0.80	223,260
300	A	0.145 15	1.00	1	1.00	22,000	1.00	1	1.00	R01	0.80	3,190

CLASS	CLASS%	DESCRIPTION			BN ID	BN	CARD	
1010	100	SINGLE FAMILY				1	1 of 1	
PMT NO	PMT DT	TY	DESC	AMOUNT	INSP	BY	1st	%
18-85	03/15/2018	3	REPAIR/REMOD	20,000	03/22/2019	JN	100	100
18-84	03/07/2018	3	REPAIR/REMOD	40,000	03/22/2019	JN	100	100
14-056	04/17/2014	10	ALL OTHERS	3,155	09/10/2014	FC	100	100
		20	NO PERMIT		05/09/2013	FC	100	100
08-148	08/04/2008	7	GARAGE	25,000	05/08/2009	JH	100	100

TOTAL	40,075 SF	ZONING	RES	FRNT	0	ASSESSED	CURRENT	PREVIOUS
Nbhd	SOUTH TRURO	N	FY03 REDUCED ACRG (2001 PLN) = SPLIT O REG+UNREG LOTS IN 2 PCLS (83+93=TITLE DIFF).			LAND	226,500	196,900
Infl1	NO ADJ	O	FY06 TITLE NOW SAME=PCL93 ACRG MERGED.			BUILDING	891,700	741,200
Infl2	NO ADJ	T				DETACHED	33,600	32,000
		E				OTHER	0	0
						TOTAL	1,151,800	970,100

TY	QUAL	COND	DIM/NOTE	YB	UNITS	ADJ PRICE	RCNLD
GUL	G	1.18 G	0.90 24*28	2003	672	55.58	33,600

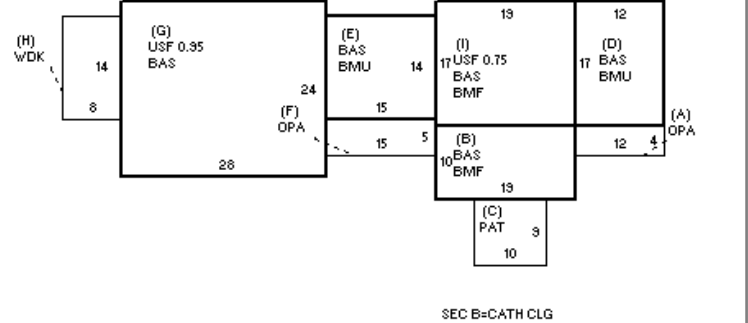

BUILDING	CD	ADJ	DESC	MEASURE	8/4/2022	LG
MODEL	1		RESIDENTIAL	LIST	8/4/2022	LG
STYLE	4	1.10	CAPE [100%]	REVIEW	12/6/2010	MR
QUALITY	+	1.15	GOOD-AVE+ [100%]			
FRAME	1	1.00	WOOD FRAME [100%]			

BLDG COMMENTS
8/4/2022 Owner confirmed interior & basement data at door (C-19). ELEC BB HEAT IN SEC G; REST OF SFR=GAS FHA.

DETACHED

BUILDING

YEAR BLT	1997	SIZE ADJ	0.995	ELEMENT	CD	DESCRIPTION	ADJ	S	BAT	T	DESCRIPTION	UNITS	YB	ADJ PRICE	RCN	TOTAL RCN	1,036,834
NET AREA	2,480	DETAIL ADJ	1.000	FOUNDATION	4	BSMT WALL	1.00	+	OPA	N	OPEN PORCH	123		99.07	12,186	CONDITION ELEM	CD
\$NLA(RCN)	\$418	OVERALL	1.110	EXT. COVER	2	CLAPBOARD	1.00	+	BMF	N	BSMT FINISH	513		181.46	93,091		
				ROOF SHAPE	1	GABLE	1.00	B	BAS	L	BAS AREA	190	1997	378.24	71,866		
				ROOF COVER	2	WOOD SHINGLES	1.01	C	PAT	N	PATIO	90		25.56	2,300		
				FLOOR COVER	1	HARDWOOD	1.00	+	BMU	N	BSMT UNFINISHED	414		103.75	42,954		
				INT. FINISH	2	DRYWALL	1.00	+	BAS	L	BAS AREA	1,409	1997	378.24	532,941		
				HEATING/COOLING	1	FORCED AIR	1.00	+	USF	L	UP-STRY FIN	881	1997	297.53	262,126		
				FUEL SOURCE	2	GAS	1.00	H	WDK	N	ATT WOOD DECK	112		76.33	8,549		
								MST	O	MASONRY STACK	1		3,821.80	3,822			
EFF.YR/AGE 2008 / 14																	
COND 14 14 %																	
FUNC 0																	
ECON 0																	
DEPR 14 % GD 86																	
RCNLD \$891,700																	