

Key: 3151

Town of TRURO - Fiscal Year 2024

9/27/2023 7:11 pm SEQ #: 3.273

LEGAL

Table with columns: CURRENT OWNER, PARCEL ID, LOCATION, TRANSFER HISTORY, DOS, T, SALE PRICE, BK-PG (Cert)

Table with columns: CLASS, CLASS%, DESCRIPTION, BN ID, BN, CARD, PMT NO, PMT DT, TY, DESC, AMOUNT, INSP, BY, 1st, %

LAND

Table with columns: CD, T, AC/SF/UN, Nbhd, Inf1, Inf2, ADJ BASE, SAF, Inf3, Lpi, VC, CREDIT AMT, ADJ VALUE

Table with columns: TOTAL, 1.550 Acres, ZONING, RES, FRNT, 0, ASSESSED, CURRENT, PREVIOUS

DETACHED

Table with columns: TY, QUAL, COND, DIM/NOTE, YB, UNITS, ADJ PRICE, RCNLD, PHOTO 03/16/2023

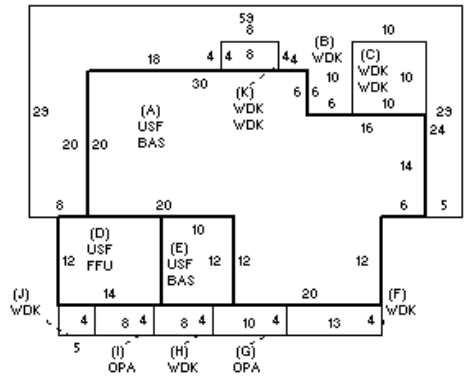

UPSIDE-DOWN HOUSE; ACCESS TO 2ND FLR VIA SPIRAL STAIRS; FDN=CRAWL FFU=MECHANICAL/STORAGE RM W/ DRY WALL WALLS+CLG

BUILDING

Table with columns: BUILDING, CD, ADJ, DESC, MEASURE, 10/15/2021, LG, LIST, 4/5/2022, LG, REVIEW, 5/26/2011, MR

BLDG COMMENTS: Per 2022 List, hardwood floors upstairs, bamboo downstairs.

INDING

Table with columns: YEAR BLT, 1972, SIZE ADJ, 0.990, ELEMENT, CD, DESCRIPTION, ADJ, S, BAT, T, DESCRIPTION, UNITS, YB, ADJ PRICE, RCN, TOTAL RCN, 986,964, EFF.YR/AGE, 1998 / 24, COND, 24 24 %, FUNC, 0, ECON, 0, DEPR, 24 % GD, 76, RCNLD, \$750,100