

Key: 3185

Town of TRURO - Fiscal Year 2024

9/27/2023 7:11 pm SEQ #: 3.303

LEGALS

CURRENT OWNER				PARCEL ID				LOCATION				
RUDYKOFF NATHANIEL T & STILMAN NAEMI				53-39-0				2 FISHER PATH				
220 WEST 148TH STREET APT 4F				TRANSFER HISTORY				DOS	T	SALE PRICE	BK-PG (Cert)	
NEW YORK, NY 10039				RUDYKOFF NATHANIEL T & RUDYKOFF FANNIE & NATHANIE				12/28/2011	99		25956-209	
								09/05/1986	99		5284-001+	

CLASS	CLASS%	DESCRIPTION			BN ID	BN	CARD	
1010	100	SINGLE FAMILY				1	1 of 1	
PMT NO	PMT DT	TY	DESC	AMOUNT	INSP	BY	1st	%
10-037	03/22/2010	1	SINGLE FAM R	400,000	05/12/2011	MR	100	100

LAND

CD	T	AC/SF/UN	Nbhd	Inf1	Inf2	ADJ BASE	SAF	Inf3	Lpi	VC	CREDIT AMT	ADJ VALUE
100	A	0.775	15	1.00	1	1.00	1	1.00	WF2	7.00		1,953,540
300	A	1.265	15	1.00	1	1.00	1	1.00	WF2	7.00		243,510

TOTAL	2.040 Acres	ZONING	RES	FRNT	0	ASSESSED	CURRENT	PREVIOUS
Nbhd	SOUTH TRURO	NOTE				LAND	2,197,100	1,910,200
Inf1	NO ADJ		BUILDING	975,600	806,300			
Inf2	NO ADJ		DETACHED	0	0			
			OTHER	0	0			
						TOTAL	3,172,700	2,716,500

DETACHED

TY	QUAL	COND	DIM/NOTE	YB	UNITS	ADJ PRICE	RCNLD	PHOTO	03/12/2020
									

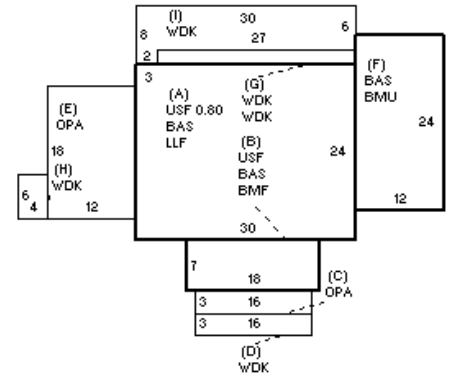

BUILDING

BUILDING	CD	ADJ	DESC	MEASURE	3/12/2020	LG	BLDG COMMENTS
MODEL	1		RESIDENTIAL	LIST	5/12/2011	EST	3/7/16: 2 Minisplits
STYLE	4	1.10	CAPE [100%]	REVIEW	3/7/2016	CF	
QUALITY	G	1.35	GOOD [100%]				
FRAME	1	1.00	WOOD FRAME [100%]				

INDING

YEAR BLT	2010	SIZE ADJ	0.990	ELEMENT	CD	DESCRIPTION	ADJ	S	BAT	T	DESCRIPTION	UNITS	YB	ADJ PRICE	RCN	TOTAL RCN	1,108,646		
NET AREA	2,556	DETAIL ADJ	1.000	FOUNDATION	3	CONTIN WALL	1.00	A	LLF	L	LOWER LEVEL FIN	720	2010	305.76	220,145	CONDITION ELEM	CD		
\$NLA(RCN)	\$434	OVERALL	1.120	EXT. COVER	1	WOOD SHINGLES	1.00	+	BAS	L	BAS AREA	1,134	2010	454.69	515,614				
				ROOF SHAPE	1	GABLE	1.00	+	USF	L	UP-STRY FIN	702	2010	354.27	248,695				
				ROOF COVER	1	ASPHALT SHINGLE	1.00	B	BMF	N	BSMT FINISH	126		213.86	26,947				
				FLOOR COVER	1	HARDWOOD	1.00	+	OPA	N	OPEN PORCH	264		105.08	27,742				
				INT. FINISH	2	DRYWALL	1.00	+	WDK	N	ATT WOOD DECK	366		76.47	27,987				
				HEATING/COOLING	2	HOT WATER	1.02	F	BMU	N	BSMT UNFINISHED	288		122.28	35,217				
				FUEL SOURCE	2	GAS	1.00	ODS	O	O	OUT DOOR SHOWER			0.00					
																EFF.YR/AGE	2010 / 12		
																COND	12 12 %		
																FUNC	0		
																ECON	0		
																DEPR	12	% GD	88
																RCNLD	\$975,600		