

Key: 3264

Town of TRURO - Fiscal Year 2024

9/27/2023 7:11 pm SEQ #: 3383

LEGAL

| CURRENT OWNER | | PARCEL ID | | LOCATION | |
|---|--|------------|----|-------------|--------------|
| ROLNICK PAUL & AMY & KEVIN C/O ROLNICK PAUL 136 ELWYN QUARRY WOODSTOCK, NY 12498 | | 54-28-0 | | 8 FISHER RD | |
| TRANSFER HISTORY | | DOS | T | SALE PRICE | BK-PG (Cert) |
| ROLNICK PAUL & AMY & KEVIN | | 02/17/2011 | 99 | 1453-1006+ | |
| ROLNICK NANCY | | 02/17/2011 | 99 | 1453-1006+ | |
| ROLNICK LOUIS & NANCY | | 10/30/1969 | 99 | 1453-1006 | |

| CLASS | CLASS% | DESCRIPTION | | BN ID | BN | CARD | |
|------------------|--------------------------|---------------|------------------|-----------------|--------------------------|--------|------------|
| 1090 | 100 | MULTIPLE HSES | | | 1 | 1 of 2 | |
| PMT NO | PMT DT | TY | DESC | AMOUNT | INSP | BY | 1st % |
| 21-333X 94-47 | 09/21/2021 05/06/1994 | 90 40 | BP NVC STUDIO | 9,860 45,000 | 11/17/2021 06/10/1994 | LG | 100 100 |

LAND

| CD | T | AC/SF/UN | Nbhd | Inf1 | Inf2 | ADJ BASE | SAF | Inf3 | Lpi | VC | CREDIT AMT | ADJ VALUE |
|-----|---|----------|------|------|------|----------|-----|------|-----|------|------------|-----------|
| 100 | A | 0.775 | 15 | 1.00 | 1 | 1.00 | 1 | 1.00 | R07 | 1.45 | | 404,660 |
| 300 | A | 0.305 | 15 | 1.00 | 1 | 1.00 | 1 | 1.00 | R07 | 1.45 | | 12,160 |

DETACHED

| TOTAL | 1.080 Acres | ZONING | RES | FRNT | 266 | ASSESSED | CURRENT | PREVIOUS |
|-------|-------------|------------------|---|---------|---------|----------|---------|----------|
| Nbhd | SOUTH TRURO | N O T E | 8/8/18 Adn'l frontage on Rose Hill Lane rescinded by Plan.Br. FY11 - RMVD LAND CODE 200 | | | LAND | 416,800 | 362,400 |
| Inf1 | NO ADJ | | BUILDING | 348,300 | 300,600 | | | |
| Inf2 | NO ADJ | | OTHER | 0 | 0 | | | |
| | | | | | TOTAL | 911,700 | 789,300 | |

| TY | QUAL | COND | DIM/NOTE | YB | UNITS | ADJ PRICE | RCNLD |
|----|------|------|----------|----|-------|-----------|-------|
| | | | | | | | |

PHOTO 04/11/2019



| BUILDING | CD | ADJ | DESC | MEASURE | 4/11/2019 | LG |
|----------|----|------|---------------------|---------|------------|----|
| MODEL | 1 | | RESIDENTIAL | LIST | 5/7/2019 | LG |
| STYLE | 8 | 1.10 | CONTEMPORARY [100%] | REVIEW | 12/13/2010 | MR |
| QUALITY | A | 1.00 | AVERAGE [100%] | | | |
| FRAME | 1 | 1.00 | WOOD FRAME [100%] | | | |

BLDG COMMENTS

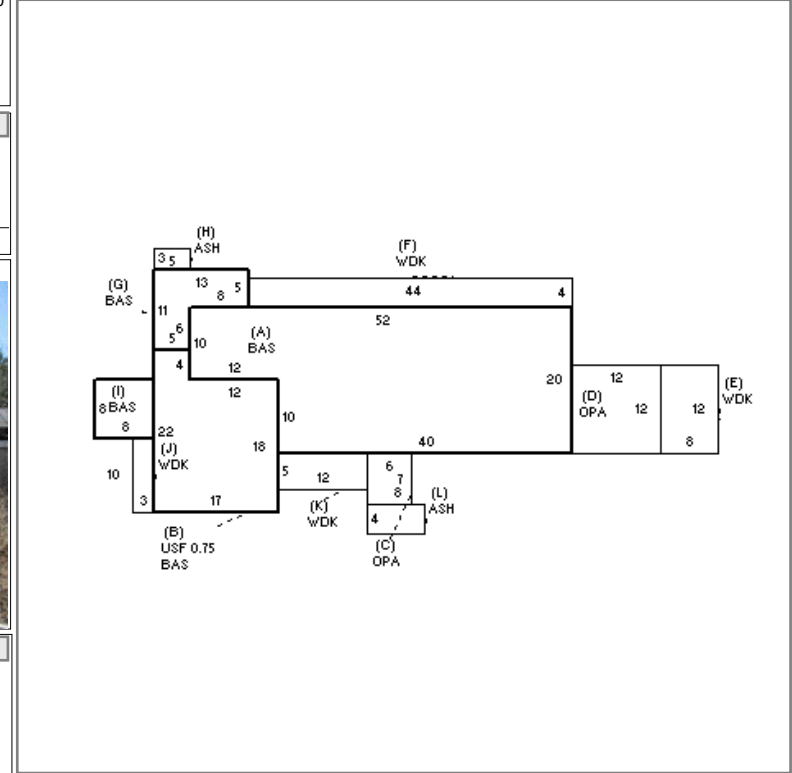

BUILDING

| YEAR BLT | 1950 | SIZE ADJ | 1.020 | ELEMENT | CD | DESCRIPTION | ADJ | S | BAT | T | DESCRIPTION | UNITS | YB | ADJ PRICE | RCN | TOTAL RCN | 590,287 |
|------------|-------|------------|-------|-----------------|----|---------------|------|-----|-----|-----------------|---------------|-------|------|-----------|---------|----------------|---------|
| NET AREA | 1,650 | DETAIL ADJ | 1.000 | FOUNDATION | | | 1.00 | + | BAS | L | BAS AREA | 1,405 | 1950 | 334.13 | 469,455 | CONDITION ELEM | CD |
| \$NLA(RCN) | \$358 | OVERALL | 1.100 | EXT. COVER | 1 | WOOD SHINGLES | 1.00 | B | USF | L | UP-STRY FIN | 245 | 1950 | 269.61 | 66,054 | | |
| | | | | ROOF SHAPE | 4 | FLAT/SHED | 1.00 | + | OPA | N | OPEN PORCH | 186 | | 83.14 | 15,465 | | |
| | | | | ROOF COVER | 7 | ROLL | 1.00 | + | WDK | N | ATT WOOD DECK | 362 | | 57.32 | 20,749 | | |
| | | | | FLOOR COVER | 6 | OTHER | 1.00 | + | ASH | N | ATT SHED | 47 | | 47.00 | 2,209 | | |
| | | | | INT. FINISH | 2 | DRYWALL | 1.00 | F11 | O | FPL 1S 1OP | 1 | | | 12,154.60 | 12,155 | | |
| | | | | HEATING/COOLING | 12 | OTHER | 1.00 | ODS | O | OUT DOOR SHOWER | | | | 0.00 | | | |
| | | | | FUEL SOURCE | 3 | ELECTRIC | 1.00 | | | | | | | | | | |

| EFF.YR/AGE | 1971 / 51 |
|------------|------------|
| COND | 41 41 % |
| FUNC | 0 |
| ECON | 0 |
| DEPR | 41 % GD 59 |
| RCNLD | \$348,300 |

Key: 3264

Town of TRURO - Fiscal Year 2024

9/27/2023 7:11 pm SEQ #: 3.384

LEGAL

| CURRENT OWNER | | PARCEL ID | LOCATION | | | |
|---|--|-----------|-------------|------------|--------------|--|
| ROLNICK PAUL & AMY & KEVIN C/O ROLNICK PAUL 136 ELWYN QUARRY WOODSTOCK, NY 12498 | | 54-28-0 | 8 FISHER RD | | | |
| TRANSFER HISTORY | | DOS | T | SALE PRICE | BK-PG (Cert) | |
| | | | | | | |

| CLASS | CLASS% | DESCRIPTION | | | BN ID | BN | CARD |
|--------|--------|---------------|------|--------|-------|----|--------|
| 1090 | 100 | MULTIPLE HSES | | | | 2 | 2 of 2 |
| PMT NO | PMT DT | TY | DESC | AMOUNT | INSP | BY | 1st % |
| | | | | | | | |

LAND

| CD | T | AC/SF/UN | Nbhd | Inf1 | Inf2 | ADJ BASE | SAF | Inf3 | Lpi | VC | CREDIT AMT | ADJ VALUE |
|----|---|----------|------|------|------|----------|-----|------|-----|----|------------|-----------|
| | | | | | | | | | | | | |

| TOTAL | ZONING | FRNT | ASSESSED | CURRENT | PREVIOUS |
|-------|--------|----------|----------|---------|----------|
| Nbhd | NOTE | | LAND | 146,600 | |
| Inf1 | | BUILDING | | | |
| Inf2 | | DETACHED | | | |
| | | | OTHER | | |
| | | | TOTAL | | |

DETACHED

| TY | QUAL | COND | DIM/NOTE | YB | UNITS | ADJ PRICE | RCNLD |
|----|------|------|----------|----|-------|-----------|-------|
| | | | | | | | |

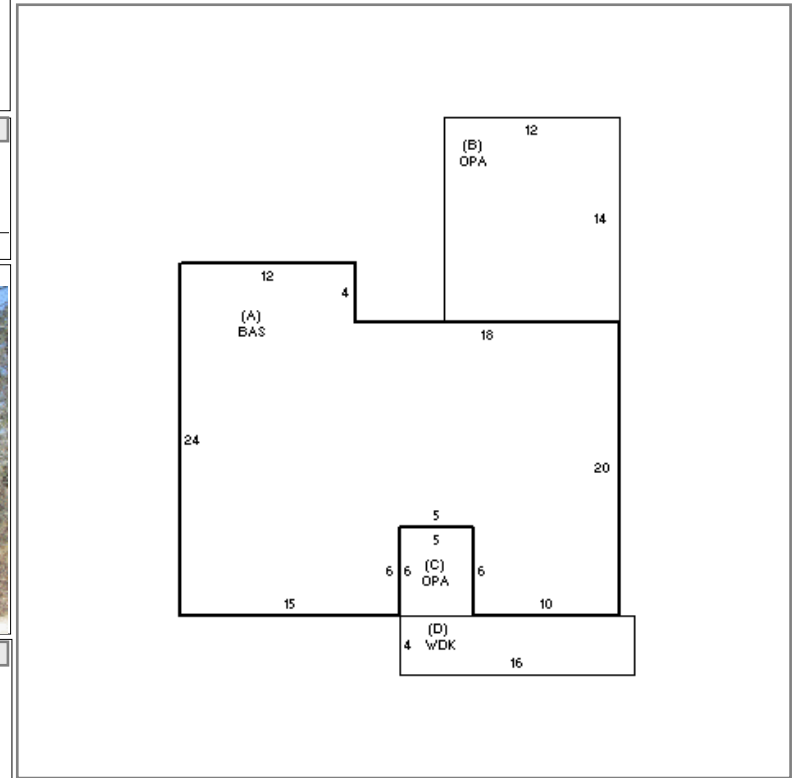

BUILDING

| BUILDING | CD | ADJ | DESC | MEASURE | 4/11/2019 | LG |
|----------|----|------|-------------------|---|------------|----|
| MODEL | 1 | | RESIDENTIAL | LIST | 5/7/2019 | LG |
| STYLE | 1 | 1.00 | RANCH [100%] | REVIEW | 12/13/2010 | MR |
| QUALITY | A | 1.00 | AVERAGE [100%] | BLDG COMMENTS | | |
| FRAME | 1 | 1.00 | WOOD FRAME [100%] | 4/11/19 Four windows recently replaced. | | |

| BLDG COMMENTS |
|---|
| 4/11/19 Four windows recently replaced. |

| YEAR BLT | 1993 | SIZE ADJ | 1.060 | ELEMENT | CD | DESCRIPTION | ADJ | S | BAT | T | DESCRIPTION | UNITS | YB | ADJ PRICE | RCN | TOTAL RCN | 206,548 |
|--------------|-------|------------|-------|-----------------|----|---------------|------|---|-----|---|-----------------|-------|------|-----------|---------|----------------|------------|
| NET AREA | 618 | DETAIL ADJ | 1.000 | FOUNDATION | | | 1.00 | A | BAS | L | BAS AREA | 618 | 1993 | 299.44 | 185,055 | CONDITION ELEM | CD |
| \$NLA(RCN) | \$334 | OVERALL | 0.930 | EXT. COVER | 1 | WOOD SHINGLES | 1.00 | + | OPA | N | OPEN PORCH | 198 | | 73.05 | 14,464 | | |
| CAPACITY | | UNITS | ADJ | ROOF SHAPE | 4 | FLAT/SHED | 1.00 | D | WDK | N | ATT WOOD DECK | 64 | | 77.02 | 4,929 | | |
| STORIES(FAR) | 1 | 1.00 | | ROOF COVER | 9 | OTHER | 1.00 | | ODS | O | OUT DOOR SHOWER | | | 0.00 | | | |
| ROOMS | 0 | 1.00 | | FLOOR COVER | 99 | N/A | 1.00 | | | | | | | | | | |
| BEDROOMS | 2 | 1.00 | | INT. FINISH | 2 | DRYWALL | 1.00 | | | | | | | | | | |
| BATHROOMS | 1 | 1.00 | | HEATING/COOLING | 13 | NO HEAT | 0.93 | | | | | | | | | | |
| FIXTURES | 3 | \$2,100 | | FUEL SOURCE | 99 | N/A | 1.00 | | | | | | | | | | |
| UNITS | 0 | 1.00 | | | | | | | | | | | | | | | |
| | | | | | | | | | | | | | | | | EFF.YR/AGE | 1993 / 29 |
| | | | | | | | | | | | | | | | | COND | 29 29 % |
| | | | | | | | | | | | | | | | | FUNC | 0 |
| | | | | | | | | | | | | | | | | ECON | 0 |
| | | | | | | | | | | | | | | | | DEPR | 29 % GD 71 |
| | | | | | | | | | | | | | | | | RCNLD | \$146,600 |