

Key: 3275

Town of TRURO - Fiscal Year 2024

9/27/2023 7:11 pm SEQ #: 3.395

LEGAL

LAND

DETACHED

BUILDING

CURRENT OWNER		PARCEL ID		LOCATION	
KACHADURIAN MARY 300 BOYLSTON ST, UNIT 502 BOSTON, MA 02116		54-41-0		67 OLD COUNTY RD	
TRANSFER HISTORY		DOS	T	SALE PRICE	BK-PG (Cert)
KACHADURIAN MARY		06/15/2010	99	(191684)	
KACHADURIAN K & MARY		09/15/2003	QS	745,000	(170536)
CIAMPA VINCENT F		03/17/2000	A	(156931)	

CLASS	CLASS%	DESCRIPTION		BN ID	BN	CARD	
1010	100	SINGLE FAMILY			1	1 of 1	
PMT NO	PMT DT	TY	DESC	AMOUNT	INSP	BY	1st %
06-201	09/01/2006	1	SINGLE FAM R	350,000	06/02/2008	JH	100 100
06-199	08/30/2006	5	DEMO	10,000	05/29/2007	JH	100 100

CD	T	AC/SF/UN	Nbhd	Inf1	Inf2	ADJ BASE	SAF	Inf3	Lpi	VC	CREDIT AMT	ADJ VALUE
100	A	0.775 15 1.00	1	1.00	1	1.00	1,080,300	1.00	1	1.00	V13 3.00	837,230
300	A	0.225 15 1.00	1	1.00	1	1.00	82,500	1.00	1	1.00	V13 3.00	18,560

TOTAL	43,560 SF	ZONING	RES	FRNT	0	ASSESSED	CURRENT	PREVIOUS
Nbhd	SOUTH TRURO	NOTE				LAND	855,800	744,100
Inf1	NO ADJ		BUILDING	1,874,600	1,611,500			
Inf2	NO ADJ		DETACHED	0	0			
			OTHER	0	0			
						TOTAL	2,730,400	2,355,600

TY	QUAL	COND	DIM/NOTE	YB	UNITS	ADJ PRICE	RCNLD



BLDG COMMENTS		
High ceilings throughout.		

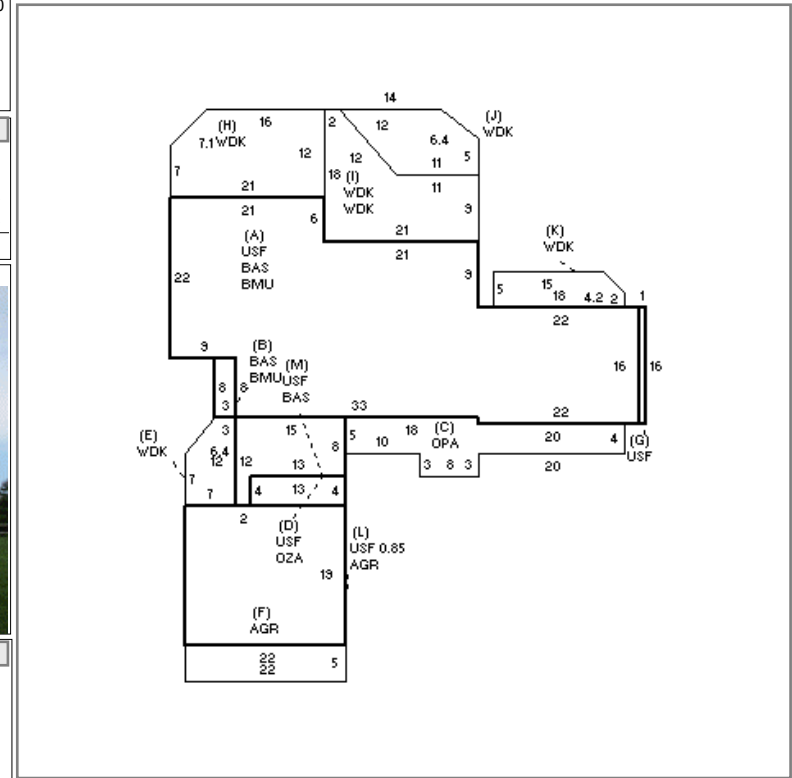

BUILDING	CD	ADJ	DESC	MEASURE	3/16/2023	LG
MODEL	1		RESIDENTIAL	LIST	5/12/2023	LG
STYLE	16	1.30	NEW STYLE [100%]	REVIEW	12/10/2010	MR
QUALITY	V	1.55	VERY GOOD [100%]			
FRAME	1	1.00	WOOD FRAME [100%]			

YEAR BLT	2006	SIZE ADJ	0.975	ELEMENT	CD	DESCRIPTION	ADJ	S	BAT	T	DESCRIPTION	UNITS	YB	ADJ PRICE	RCN	TOTAL RCN	2,231,640
NET AREA	3,455	DETAIL ADJ	1.020	FOUNDATION	4	BSMT WALL	1.00	+	BMU	N	BSMT UNFINISHED	1,438		129.27	185,885		
\$NLA(RCN)	\$646	OVERALL	1.330	EXT. COVER	1	WOOD SHINGLES	1.00	A	BAS	L	BAS AREA	1,414	2006	598.57	846,373		
				ROOF SHAPE	1	GABLE	1.00	A	USF	L	UP-STRY FIN	1,414	2006	441.72	624,592		
				ROOF COVER	1	ASPHALT SHINGLE	1.00	C	OPA	N	OPEN PORCH	194		148.93	28,893		
				FLOOR COVER	1	HARDWOOD	1.00	D	OZA	N	OPEN BRZWAY	128		107.74	13,790		
				INT. FINISH	2	DRYWALL	1.00	+	WDK	N	ATT WOOD DECK	1,011		90.60	91,596		
				HEATING/COOLING	9	WARM/COOL AIR	1.03	+	AGR	N	ATTACHED GARAGE	528		185.78	98,092		
				FUEL SOURCE	2	GAS	1.00	+	USF	L	UP-STRY FIN	551	2006	441.72	243,388		
								+	BAS	L	BAS AREA	76	2006	598.57	45,492		
									F22	O	FPL 2S 2OP	1		42,337.90	42,338		
									ODS	O	OUT DOOR SHOWER	1		0.00			

CONDITION ELEM	CD

EFF. YR/AGE	2006 / 16
COND	16 16 %
FUNC	0
ECON	0
DEPR	16 % GD 84
RCNLD	\$1,874,600