

Key: 3445

Town of TRURO - Fiscal Year 2024

9/27/2023 7:11 pm SEQ #: 3.577

LEGAL

CURRENT OWNER				PARCEL ID				LOCATION			
RENTEL RONALD & BARBARA 371 W 123rd ST, APT 6C NEW YORK, NY 10027				58-58-0				2 STURDY WAY			
TRANSFER HISTORY				DOS	T	SALE PRICE	BK-PG (Cert)				
RENTEL RONALD & BARBARA				06/16/2014	O	775,000	28207-22				
SHEPHERDSON ELIZABETH ANN				12/30/1987	QS	110,000	6084-002				

CLASS	CLASS%	DESCRIPTION			BN ID	BN	CARD	
1010	100	SINGLE FAMILY				1	1 of 1	
PMT NO	PMT DT	TY	DESC	AMOUNT	INSP	BY	1st	%
14-263	12/15/2014	30	CHECK DATA		12/18/2014	FC	100	100
14-214	10/08/2014	90	REPAIR/REMOD	80,000	09/17/2015	FC	100	100
87-123	07/29/1987	1	BP NVC	10,000	12/18/2014	FC	100	100
			SINGLE FAM R	150,000	12/31/1988	SW	100	100

LAND

CD	T	AC/SF/UN	Nbhd	Inf1	Inf2	ADJ BASE	SAF	Inf3	Lpi	VC	CREDIT AMT	ADJ VALUE
100	A	0.775	15	1.00	1	1.00	1	1.00	R09	2.00		558,160
300	A	0.345	15	1.00	1	1.00	1	1.00	R09	2.00		18,980

DETACHED

TOTAL	1.120 Acres		ZONING	RES	FRNT	0	ASSESSED	CURRENT	PREVIOUS
Nbhd	SOUTH TRURO		NOTE				LAND	577,100	401,400
Inf1	NO ADJ			BUILDING	703,200	596,700			
Inf2	NO ADJ			DETACHED	100	100			
				OTHER	0	0	<b>TOTAL</b>	<b>1,280,400</b>	<b>998,200</b>

TY	QUAL	COND	DIM/NOTE	YB	UNITS	ADJ PRICE	RCNLD	PHOTO	05/21/2019
PTD	A	1.00	A 0.75 6*10		60	2.30	100		

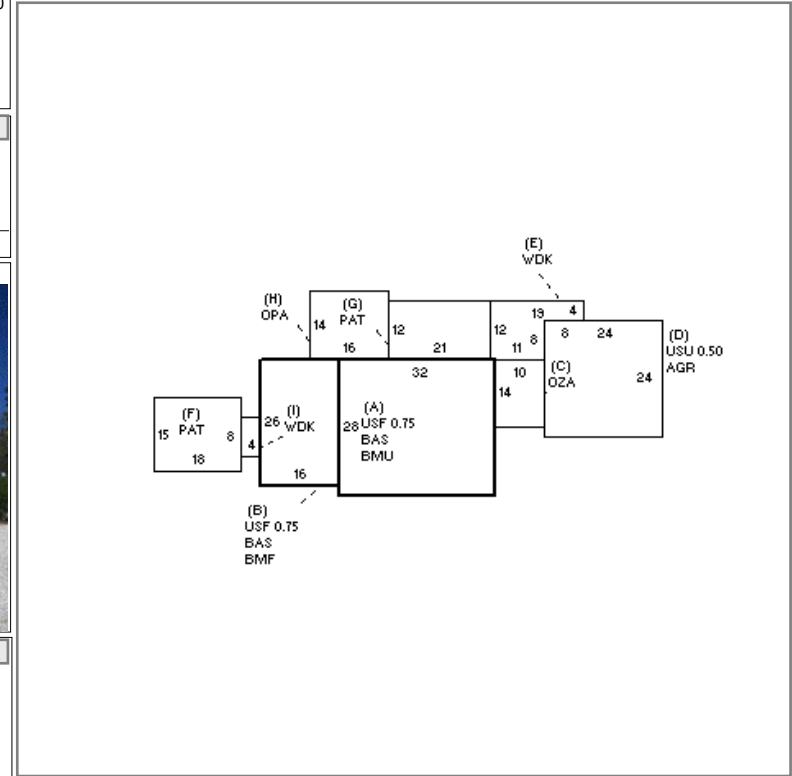

BUILDING

BUILDING	CD	ADJ	DESC	MEASURE	5/21/2019	LG
MODEL	1		RESIDENTIAL	LIST	8/11/2010	EST
STYLE	4	1.10	CAPE [100%]	REVIEW	12/13/2010	MR
QUALITY	A	1.00	AVERAGE [100%]			
FRAME	1	1.00	WOOD FRAME [100%]			

YEAR BLT	1988	SIZE ADJ	0.995	ELEMENT	CD	DESCRIPTION	ADJ	S	BAT	T	DESCRIPTION	UNITS	YB	ADJ PRICE	RCN
NET AREA	2,296	DETAIL ADJ	1.000	FOUNDATION	4	BSMT WALL	1.00	A	BMU	N	BSMT UNFINISHED	896		80.35	71,993
\$NLA(RCN)	\$438	OVERALL	1.120	EXT. COVER	1	WOOD SHINGLES	1.00	+	BAS	L	BAS AREA	1,312	1988	335.19	439,766
				ROOF SHAPE	1	GABLE	1.00	+	USF	L	UP-STRY FIN	984	1988	261.05	256,877
				ROOF COVER	1	ASPHALT SHINGLE	1.00	B	BMF	N	BSMT FINISH	416		159.21	66,233
				FLOOR COVER	2	SOFTWOOD	1.00	C	OZA	N	OPEN BRZWAY	140		59.73	8,363
				INT. FINISH	2	DRYWALL	1.00	D	AGR	N	ATTACHED GARAGE	576		100.72	58,012
				HEATING/COOLING	2	HOT WATER	1.02	D	USU	N	UPPER STORY UNF	288		148.22	42,686
				FUEL SOURCE	1	OIL	1.00	+	WDK	N	ATT WOOD DECK	196		63.63	12,471
								+	PAT	N	PATIO	522		14.63	7,635
								H	OPA	N	OPEN PORCH	224		78.23	17,524
								F21	O	FPL 2S 1OP	1		16,767.30	16,767	
								ODS	O	OUT DOOR SHOWER			0.00		

TOTAL RCN	1,004,626	
CONDITION ELEM	CD	
EFF.YR/AGE	1989 / 33	
COND	30	30 %
FUNC	0	
ECON	0	
DEPR	30	% GD 70
RCNLD	\$703,200	