

Key: 3453

Town of TRURO - Fiscal Year 2024

9/27/2023 7:11 pm SEQ #: 3.585

LEGAL

CURRENT OWNER		PARCEL ID	LOCATION			
16 QUANSET ROAD REALTY TRUST TRS: CANDACE A FOSTER 9 JUNIPER RIDGE RD LINCOLN, MA 01773		58-66-0	16 QUANSET RD			
TRANSFER HISTORY		DOS	T	SALE PRICE	BK-PG (Cert)	
16 QUANSET ROAD REALTY TR FOSTER CANDACE A FOSTER GERALD L & CANDICE		10/28/2021 08/10/2005 07/12/1985	F 99 99		1 (228046) (177598) (102483)	

CLASS	CLASS%	DESCRIPTION			BN ID	BN	CARD	
1010	100	SINGLE FAMILY				1	1 of 1	
PMT NO	PMT DT	TY	DESC	AMOUNT	INSP	BY	1st	%
01-224	12/20/2001	1	SINGLE FAM R	175,000	06/28/2003	TEG	100	100

LAND

CD	T	AC/SF/UN	Nbhd	Inf1	Inf2	ADJ BASE	SAF	Inf3	Lpi	VC	CREDIT AMT	ADJ VALUE
100	A	0.775 15 1.00		1 1.00	1 1.00	720,200	1.00	1 1.00	R09	2.00		558,160
300	A	0.085 15 1.00		1 1.00	1 1.00	55,000	1.00	1 1.00	R09	2.00		4,680

TOTAL	37,462 SF	ZONING	RES	FRNT	0	ASSESSED	CURRENT	PREVIOUS
Nbhd	SOUTH TRURO	NOTE				LAND	562,800	391,500
Inf1	NO ADJ		BUILDING	1,179,500	975,700			
Inf2	NO ADJ		DETACHED	2,900	2,800			
			OTHER	0	0			
						TOTAL	1,745,200	1,370,000

DETACHED

TY	QUAL	COND	DIM/NOTE	YB	UNITS	ADJ PRICE	RCNLD
HTB	G	1.18 G 0.90		2002	1	3,221.87	2,900

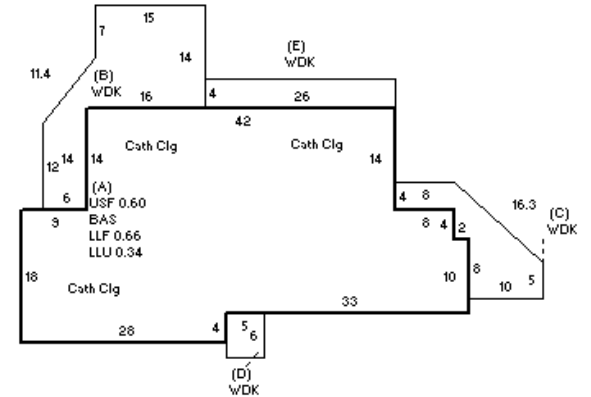

BUILDING

BUILDING	CD	ADJ	DESC	MEASURE	11/16/2021	LG
MODEL	1		RESIDENTIAL	LIST	10/3/2012	EST
STYLE	4	1.10	CAPE [100%]	REVIEW	4/6/2021	MR
QUALITY	G	1.35	GOOD [100%]			
FRAME	1	1.00	WOOD FRAME [100%]			

BLDG COMMENTS
MODULAR HOME

YEAR BLT	2002	SIZE ADJ	0.975	ELEMENT	CD	DESCRIPTION	ADJ	S	BAT	T	DESCRIPTION	UNITS	YB	ADJ PRICE	RCN	TOTAL RCN	1,474,341		
NET AREA	3,494	DETAIL ADJ	1.000	FOUNDATION	4	BSMT WALL	1.00	A	LLU	N	LOWER LEVEL UNF	526		225.33	118,523	CONDITION ELEM	CD		
\$NLA(RCN)	\$422	OVERALL	1.100	EXT. COVER	1	WOOD SHINGLES	1.00	A	LLF	L	LOWER LEVEL FIN	1,020	2002	284.59	290,277				
				ROOF SHAPE	1	GABLE	1.00	A	BAS	L	BAS AREA	1,546	2002	431.18	666,600				
				ROOF COVER	1	ASPHALT SHINGLE	1.00	A	USF	L	UP-STRY FIN	928	2002	339.17	314,752				
				FLOOR COVER	3	W/W CARPET	1.00	+	WDK	N	ATT WOOD DECK	588		65.26	38,375				
				INT. FINISH	2	DRYWALL	1.00	WDK	N	ATT WOOD DECK	584		65.26	38,114					
				HEATING/COOLING	1	FORCED AIR	1.00												
				FUEL SOURCE	2	GAS	1.00												
																		EFF.YR/AGE	2002 / 20
																		COND	20 20 %
																		FUNC	0
																		ECON	0
																		DEPR	20 % GD 80
																		RCNLD	\$1,179,500