

Key: 3456

Town of TRURO - Fiscal Year 2024

9/27/2023 7:11 pm SEQ #: 3.588

LEGAL

LAND

DETACHED

BUILDING

CURRENT OWNER		PARCEL ID		LOCATION	
MICHAEL S HAYNES 2016 REVOC TR TRS: HAYNES MICHAEL S PO BOX 1040 TRURO, MA 02666		58-69-0		17 SANDPIPER RD	
TRANSFER HISTORY		DOS	T	SALE PRICE	BK-PG (Cert)
MICHAEL S HAYNES 2016 REV		02/14/2017	F	1 (212069)	
HAYNES MICHAEL S & CATHER		03/30/2001	G	450,000 (161052)	
FISCHMAN NANCY K		12/23/1992	99	(128799)	

CLASS	CLASS%	DESCRIPTION		BN ID	BN	CARD	
1010	100	SINGLE FAMILY			1	1 of 2	
PMT NO	PMT DT	TY	DESC	AMOUNT	INSP	BY	1st %
18-202X	06/14/2018	90	BP NVC	3,050	06/25/2019	JN	100 100
17-303	10/31/2017	7	GARAGE	225,000	01/07/2019	LG	100 100
15-235	09/28/2015	90	BP NVC	10,230			100 100
02-187	09/23/2002	1	SINGLE FAM R	35,000	04/08/2004	BT	100 100

CD	T	AC/SF/UN	Nbhd	Inf1	Inf2	ADJ BASE	SAF	Inf3	Lpi	VC	CREDIT AMT	ADJ VALUE
100	A	0.775	15	1.00	1	1.00	1	1.00	990,275	1.00	1	767,460
300	A	0.135	15	1.00	1	1.00	1	1.00	75,625	1.00	1	10,210
350	A	0.130	15	1.00	1	1.00	1	1.00	6,900	1.00	1	900

TOTAL	1.040 Acres	ZONING	RES	FRNT	0	ASSESSED	CURRENT	PREVIOUS
Nbhd	SOUTH TRURO	NOTE				LAND	778,600	492,500
Inf1	NO ADJ					BUILDING	1,370,900	1,134,100
Inf2	NO ADJ					DETACHED	500	500
						OTHER	488,300	403,100
						TOTAL	2,638,300	2,030,200

TY	QUAL	COND	DIM/NOTE	YB	UNITS	ADJ PRICE	RCNLD
PTD	A	1.00	A 0.75 FRONT, IRREG	2003	292	2.30	500



BLDG COMMENTS
BR/BA/FIXT COUNT PER PLANS.

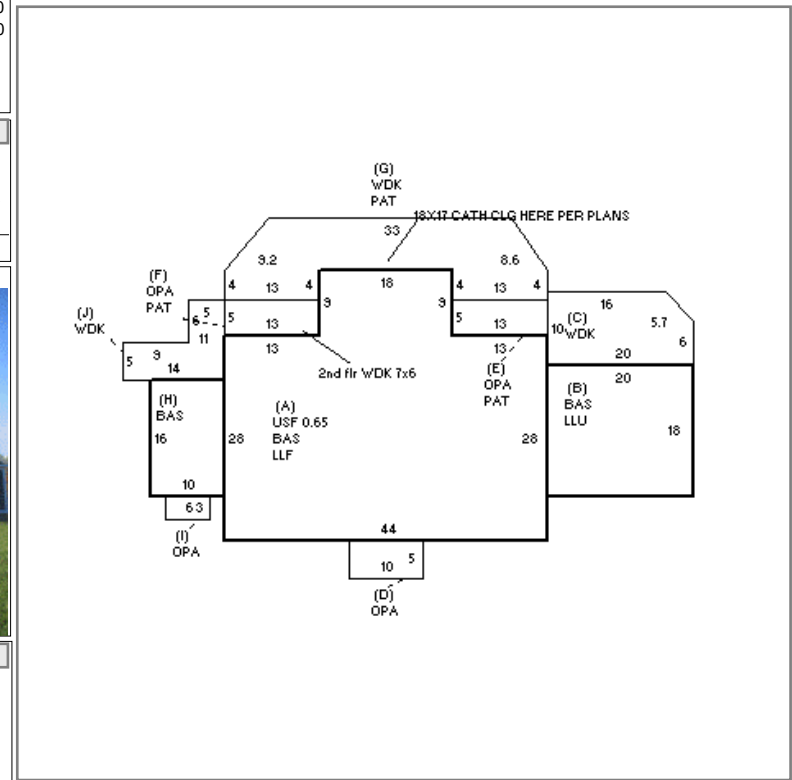

BUILDING	CD	ADJ	DESC	MEASURE	11/17/2021	LG
MODEL	1		RESIDENTIAL	LIST	10/15/2012	EST
STYLE	4	1.10	CAPE [100%]	REVIEW	4/6/2021	MR
QUALITY	G	1.35	GOOD [100%]			
FRAME	1	1.00	WOOD FRAME [100%]			

YEAR BLT	2002	SIZE ADJ	0.970	ELEMENT	CD	DESCRIPTION	ADJ	S	BAT	T	DESCRIPTION	UNITS	YB	ADJ PRICE	RCN
NET AREA	4,214	DETAIL ADJ	1.000	FOUNDATION	4	BSMT WALL	1.00	A	LLF	L	LOWER LEVEL FIN	1,394	2002	285.45	397,914
\$NLA(RCN)	\$407	OVERALL	1.120	EXT. COVER	1	WOOD SHINGLES	1.00	+	BAS	L	BAS AREA	1,754	2002	428.03	750,764
				ROOF SHAPE	1	GABLE	1.00	A	USF	L	UP-STRY FIN	906	2002	343.57	311,272
				ROOF COVER	1	ASPHALT SHINGLE	1.00	B	LLU	N	LOWER LEVEL UNF	360		228.25	82,170
				FLOOR COVER	1	HARDWOOD	1.00	+	WDK	N	ATT WOOD DECK	666		66.11	44,029
				INT. FINISH	1	PLASTER	1.00	+	OPA	N	OPEN PORCH	198		108.68	21,519
				HEATING/COOLING	2	HOT WATER	1.02	+	PAT	N	PATIO	504		19.25	9,702
				FUEL SOURCE	1	OIL	1.00	H	BAS	L	BAS AREA	160	2018	428.03	68,485
									WDK	N	ATT WOOD DECK	42		127.81	5,368
									GFP	O	GAS FIREPLACE	1		13,240.80	13,241
									ODS	O	OUT DOOR SHOWER	1		0.00	

TOTAL RCN	1,713,563
CONDITION ELEM	CD
EFF.YR/AGE	2002 / 20
COND	20 20 %
FUNC	0
ECON	0
DEPR	20 % GD 80
RCNLD	\$1,370,900

Key: 3456

Town of TRURO - Fiscal Year 2024

9/27/2023 7:11 pm SEQ #: 3.589

LEGAL

CURRENT OWNER				PARCEL ID				LOCATION			
MICHAEL S HAYNES 2016 REVOC TR				58-69-0				17 SANDPIPER RD			
TRS: HAYNES MICHAEL S				TRANSFER HISTORY				DOS	T	SALE PRICE	BK-PG (Cert)
PO BOX 1040											
TRURO, MA 02666											

CLASS	CLASS%	DESCRIPTION				BN ID	BN	CARD	
1010	100	SINGLE FAMILY					2	2 of 2	
PMT NO	PMT DT	TY	DESC	AMOUNT	INSP	BY	1st	%	

LAND

CD	T	AC/SF/UN	Nbhd	Inf1	Inf2	ADJ BASE	SAF	Inf3	Lpi	VC	CREDIT AMT	ADJ VALUE

TOTAL	ZONING	FRNT	ASSESSED	CURRENT	PREVIOUS
Nbhd	NOTE		LAND	488,300	
Inf1		BUILDING			
Inf2		DETACHED			
			OTHER		
			TOTAL		

DETACHED

TY	QUAL	COND	DIM/NOTE	YB	UNITS	ADJ PRICE	RCNLD	PHOTO
								07/30/2018
								

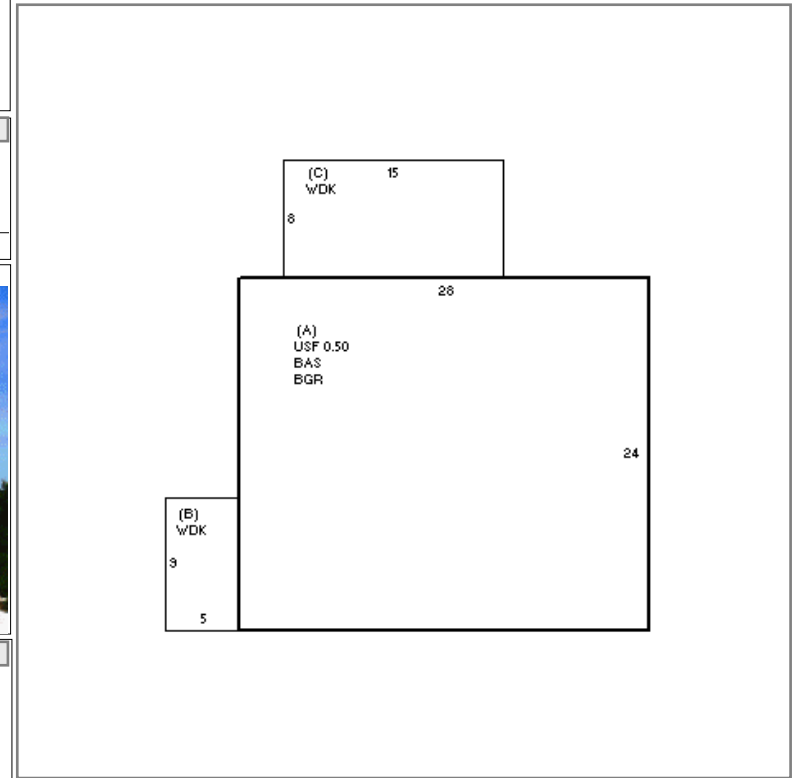

BUILDING

BUILDING	CD	ADJ	DESC	MEASURE	7/30/2018	LG
MODEL	1		RESIDENTIAL	LIST	1/7/2019	LG
STYLE	17	1.00	GAR W/QTRS [100%]	REVIEW		
QUALITY	G	1.35	GOOD [100%]			
FRAME	1	1.00	WOOD FRAME [100%]			

YEAR BLT	2016	SIZE ADJ	1.040	ELEMENT	CD	DESCRIPTION	ADJ	S	BAT	T	DESCRIPTION	UNITS	YB	ADJ PRICE	RCN
NET AREA	1,008	DETAIL ADJ	1.000	FOUNDATION	4	BSMT WALL	1.00	A	BGR	N	SF BSMT GARAGE	672		128.43	86,304
\$NLA(RCN)	\$510	OVERALL	1.030	EXT. COVER	1	WOOD SHINGLES	1.00	A	BAS	L	BAS AREA	672	2016	439.27	295,188
				ROOF SHAPE	1	GABLE	1.00	A	USF	L	UP-STRY FIN	336	2016	347.49	116,757
				ROOF COVER	1	ASPHALT SHINGLE	1.00	+	WDK	N	ATT WOOD DECK	165		82.57	13,624
				FLOOR COVER	6	OTHER	1.00								
				INT. FINISH	5	OTHER	1.00								
				HEATING/COOLING	9	WARM/COOL AIR	1.03								
				FUEL SOURCE	7	OTHER	1.00								

TOTAL RCN	513,973
CONDITION ELEM	CD
EFF.YR/AGE	2017 / 5
COND	05 05%
FUNC	0
ECON	0
DEPR	5 % GD 95
RCNLD	\$488,300