

Key: 3546

Town of TRURO - Fiscal Year 2024

9/27/2023 7:11 pm SEQ #: 3.688

LEGAL

| CURRENT OWNER | | | | PARCEL ID | | | | LOCATION | | | |
|---|--|--|--|------------|----|------------|--|--------------|--|--|--|
| LEFF DREW M & SUSAN W 112 BEACH ST BOSTON, MA 02111 | | | | 59-94-0 | | | | 9 MARC LN | | | |
| TRANSFER HISTORY | | | | DOS | T | SALE PRICE | | BK-PG (Cert) | | | |
| LEFF DREW M & SUSAN W | | | | 12/04/1986 | 99 | | | (109020) | | | |

| CLASS | CLASS% | DESCRIPTION | | | BN ID | BN | CARD | |
|--------|------------|---------------|----------|---------|------------|----|--------|-----|
| 1010 | 100 | SINGLE FAMILY | | | | 1 | 1 of 1 | |
| PMT NO | PMT DT | TY | DESC | AMOUNT | INSP | BY | 1st | % |
| 15-011 | 01/29/2015 | 90 | BP NVC | 2,500 | 10/05/2015 | FC | 100 | 100 |
| 05-185 | 10/28/2005 | 2 | ADDITION | 200,000 | 06/01/2007 | JH | 100 | 100 |

LAND

| CD | T | AC/SF/UN | Nbhd | Inf1 | Inf2 | ADJ BASE | SAF | Inf3 | Lpi | VC | CREDIT AMT | ADJ VALUE |
|-----|---|---------------|------|------|------|----------|------|------|------|-----|------------|-----------|
| 100 | A | 0.775 15 1.00 | 1 | 1.00 | 1 | 720,200 | 1.00 | 1 | 1.00 | R09 | 2.00 | 558,160 |
| 300 | A | 0.005 15 1.00 | 1 | 1.00 | 1 | 55,000 | 1.00 | 1 | 1.00 | R09 | 2.00 | 280 |

| | | | | | | | | |
|-------|-------------|--------|----------|---------|---------|-----------|---------|----------|
| TOTAL | 33,977 SF | ZONING | RES | FRNT | 0 | ASSESSED | CURRENT | PREVIOUS |
| Nbhd | SOUTH TRURO | NOTE | | | LAND | 558,400 | 388,400 | |
| Inf1 | NO ADJ | | BUILDING | 603,200 | 496,100 | | | |
| Inf2 | NO ADJ | | DETACHED | 0 | 0 | | | |
| | | | OTHER | 0 | 0 | | | |
| | | | | | TOTAL | 1,161,600 | 884,500 | |

DETACHED

| TY | QUAL | COND | DIM/NOTE | YB | UNITS | ADJ PRICE | RCNLD |
|----|------|------|----------|----|-------|-----------|-------|
| | | | | | | | |

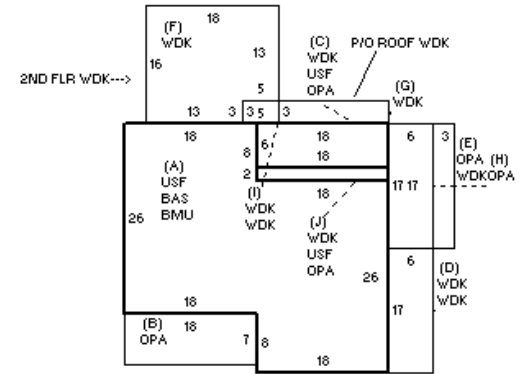

BLDG COMMENTS

BUILDING

| BUILDING | CD | ADJ | DESC | MEASURE | 10/5/2015 | FC |
|----------|----|------|-------------------|---------|------------|----|
| MODEL | 1 | | RESIDENTIAL | LIST | 10/5/2015 | FC |
| STYLE | 5 | 1.05 | COLONIAL [100%] | REVIEW | 12/13/2010 | MR |
| QUALITY | + | 1.15 | GOOD-AVE+ [100%] | | | |
| FRAME | 1 | 1.00 | WOOD FRAME [100%] | | | |

LOADING

| YEAR BLT | 1985 | SIZE ADJ | 1.000 | ELEMENT | CD | DESCRIPTION | ADJ | S | BAT | T | DESCRIPTION | UNITS | YB | ADJ PRICE | RCN | TOTAL RCN | 773,298 | | |
|------------|-------|------------|-------|-----------------|----|-----------------|------|-----|-----|-----------------|-----------------|-------|------|-----------|---------|----------------|-----------|------|----|
| NET AREA | 2,016 | DETAIL ADJ | 1.000 | FOUNDATION | 4 | BSMT WALL | 1.00 | A | BMU | N | BSMT UNFINISHED | 936 | | 82.92 | 77,609 | CONDITION ELEM | CD | | |
| \$NLA(RCN) | \$384 | OVERALL | 1.000 | EXT. COVER | 2 | CLAPBOARD | 1.00 | A | BAS | L | BAS AREA | 936 | 1985 | 349.32 | 326,963 | | | | |
| | | | | ROOF SHAPE | 1 | GABLE | 1.00 | + | USF | L | UP-STRY FIN | 972 | 1985 | 266.62 | 259,150 | | | | |
| | | | | ROOF COVER | 1 | ASPHALT SHINGLE | 1.00 | + | OPA | N | OPEN PORCH | 423 | | 71.76 | 30,354 | | | | |
| | | | | FLOOR COVER | 1 | HARDWOOD | 1.00 | C | USF | L | UP-STRY FIN | 108 | 2005 | 266.62 | 28,795 | | | | |
| | | | | INT. FINISH | 2 | DRYWALL | 1.00 | + | WDK | N | ATT WOOD DECK | 798 | | 51.84 | 41,366 | | | | |
| | | | | HEATING/COOLING | 5 | ELECTRIC | 0.95 | MST | O | MASONRY STACK | 1 | | | 3,460.40 | 3,460 | | | | |
| | | | | FUEL SOURCE | 3 | ELECTRIC | 1.00 | ODS | O | OUT DOOR SHOWER | | | | 0.00 | | | | | |
| | | | | | | | | | | | | | | | | EFF.YR/AGE | 2000 / 22 | | |
| | | | | | | | | | | | | | | | | COND | 22 22 % | | |
| | | | | | | | | | | | | | | | | FUNC | 0 | | |
| | | | | | | | | | | | | | | | | ECON | 0 | | |
| | | | | | | | | | | | | | | | | DEPR | 22 | % GD | 78 |
| | | | | | | | | | | | | | | | | RCNLD | \$603,200 | | |