

Key: 5566

Town of TRURO - Fiscal Year 2024

9/27/2023 7:11 pm SEQ #: 3.886

LEGAL

LAND

DETACHED

BUILDING

CURRENT OWNER				PARCEL ID				LOCATION				
KINNEALEY JOSEPH 11 HUTCHINSON LN QUINCY, MA 02171				53-99-0				2 WELL SWEEP LN				
TRANSFER HISTORY				DOS	T	SALE PRICE	BK-PG (Cert)					
KINNEALEY JOSEPH				03/23/2018	QS	1,320,000	31156-198					
FRANCIS THOMAS S & MARIE				11/27/2000	QS	174,000	13388-090					
HADLEY ERNEST C &				11/15/1999	G	585,000	12664-044					
CD	T	AC/SF/UN	Nbhd	Inf1	Inf2	ADJ BASE	SAF	Inf3	Lpi	VC	CREDIT AMT	ADJ VALUE
100	A	0.775 15 1.00		1 1.00	1 1.00	576,160	1.00	1 1.00	R08	1.60		446,520
300	A	0.005 15 1.00		1 1.00	1 1.00	44,000	1.00	1 1.00	R08	1.60		220

TOTAL	33,977 SF	ZONING	RES	FRNT	0	ASSESSED	CURRENT	PREVIOUS
Nbhd	SOUTH TRURO	N O T E	ST1 (HOME OFFICE W/ELECTR WALL HEATER, HALF-BATH & WDK) ATTACHED TO GARAGE.			LAND	446,700	388,400
Inf1	NO ADJ		BUILDING	1,310,500	1,085,900			
Inf2	NO ADJ		DETACHED	44,300	40,500			
						OTHER	0	0
						TOTAL	1,801,500	1,514,800

TY	QUAL	COND	DIM/NOTE	YB	UNITS	ADJ PRICE	RCNLD
ST1	G	1.18 G	0.90 14*23	2006	322	112.57	32,600
DGF	G	1.18 G	0.90 17*24	2006	408	28.19	10,400
SHF	A	1.00 A	0.75 8*10	2007	80	16.47	1,000
CAN	A	1.00 A	0.75 2*10 ON SHF	20	20	7.20	100
WDK	A	1.00 A	0.75 ON ST1 4*6	2006	24	11.00	200



BLDG COMMENTS  
Garage/Boathouse connected to Studio/Home Office.  
2.5 baths in house, half bath in Studio

CLASS	CLASS%	DESCRIPTION		BN ID	BN	CARD	
1010	100	SINGLE FAMILY			1	1 of 1	
PMT NO	PMT DT	TY	DESC	AMOUNT	INSP	BY	1st %
20-048	02/19/2020	3	REPAIR/REMOD	40,000	11/06/2020	LG	100 100
07-111	05/30/2007	6	SHED	4,000	06/02/2008	JH	100 100
06-164	07/26/2006	7	GARAGE		05/29/2007	JH	100 100
06-156	07/14/2006	1	SINGLE FAM R	600,000	05/29/2007	JH	100 100

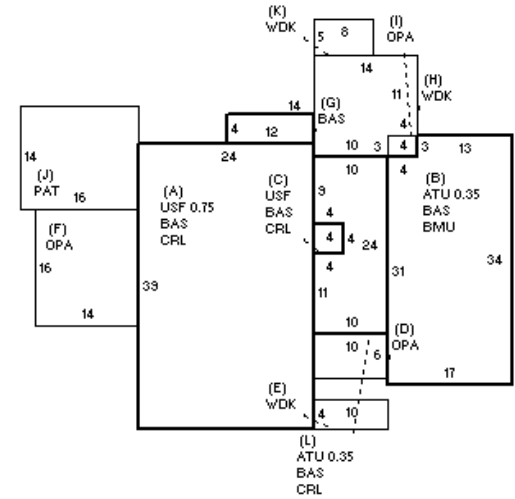

BUILDING	CD	ADJ	DESC	MEASURE	3/16/2023	LG								TOTAL RCN	1,523,837						
MODEL	1		RESIDENTIAL	LIST	5/12/2023	LG								CONDITION ELEM CD							
STYLE	4	1.10	CAPE [100%]	REVIEW	12/13/2010	MR															
QUALITY	V	1.55	VERY GOOD [100%]																		
FRAME	1	1.00	WOOD FRAME [100%]																		
YEAR BLT	2006	SIZE ADJ	0.990	ELEMENT	CD	DESCRIPTION	ADJ	S	BAT	T	DESCRIPTION	UNITS	YB	ADJ PRICE	RCN	TOTAL RCN	1,523,837				
NET AREA	2,508	DETAIL ADJ	1.000	FOUNDATION	4	BSMT WALL	1.00	+	CRL	N	CRAWL SPACE	1,176		60.07	70,644						
\$NLA(RCN)	\$608	OVERALL	1.130	EXT. COVER	1	WOOD SHINGLES	1.00	+	USF	L	UP-STRY FIN	718	2006	410.38	294,654						
CAPACITY			UNITS	ADJ	ROOF SHAPE	1	GABLE	1.00	B	BMU	N	BSMT UNFINISHED	566	141.65	80,173						
STORIES(FAR)	1.75	1.00	ROOF COVER	1	ASPHALT SHINGLE	1.00	+	ATU	N	UNFIN ATTIC	277		140.96	39,046							
ROOMS	7	1.00	FLOOR COVER	2	SOFTWOOD	1.00	+	OPA	N	OPEN PORCH	296		121.72	36,031							
BEDROOMS	3	1.00	INT. FINISH	2	DRYWALL	1.00	+	WDK	N	ATT WOOD DECK	264		93.79	24,761							
BATHROOMS	2.5	1.00	HEATING/COOLING	9	WARM/COOL AIR	1.03	+	BAS	L	BAS AREA	1,790	2006	508.63	910,457							
FIXTURES	8	\$5,600	FUEL SOURCE	2	GAS	1.00	J	PAT	N	PATIO	224		27.31	6,118							
UNITS	0	1.00								F23	O	FPL 2S 3OP	1		56,354.50	56,355					
														ODS	O	OUT DOOR SHOWER	2		0.00		
																EFF.YR/AGE	2008 / 14				
																COND	14 14 %				
																FUNC	0				
																ECON	0				
																DEPR	14 % GD 86				
																RCNLD	\$1,310,500				