

Key: 5581

Town of TRURO - Fiscal Year 2024

9/27/2023 7:11 pm SEQ #: 3.901

LEG
A
L
L
A
N
D

CURRENT OWNER										PARCEL ID			LOCATION			
PYENSON ERIC & ANDREA 32 AMHERST RD WABAN, MA 02468										50-288-0			51 DEPOT RD			
TRANSFER HISTORY										DOS	T	SALE PRICE	BK-PG (Cert)			
PYENSON ERIC & ANDREA										12/13/2019	O	950,000	32545-9			
WILLIAM C BRENNAN TRUST E										10/21/2014	F		28458-56			
BRENNAN WILLIAM C & SUSAN										06/26/2008	A	545,000	23006-222			
CD	T	AC/SF/UN	Nbhd	Inf1	Inf2	ADJ BASE	SAF	Inf3	Lpi	VC	CREDIT AMT	ADJ VALUE				
100	A	0.775	15	1.00	1	1,080,300	1.00	1	1.00	V13		837,230				
300	A	0.305	15	1.00	1	82,500	1.00	1	1.00	V13		25,160				
350	A	0.160	15	1.00	1	6,900	1.00	1	1.00	TWP		1,100				

CLASS	CLASS%	DESCRIPTION			BN ID	BN	CARD	
1040	100	TWO FAMILY				1	1 of 1	
PMT NO	PMT DT	TY	DESC	AMOUNT	INSP	BY	1st	%
21-005	01/04/2021	80	SOLAR TAXABL	18,500	12/07/2021	LG	100	100
20-357	11/24/2020	2	ADDITION	380,000	11/17/2021	LG	100	100
18-80X	03/07/2018	90	BP NVC	1,600			100	100
	01/19/2007	30	CHECK DATA		06/02/2008	JH	100	100
	01/01/2002	50	SPLIT SUB				100	100

TOTAL	1.240 Acres	ZONING	RES	FRNT	0	ASSESSED	CURRENT	PREVIOUS
Nbhd	SOUTH TRURO	NOTE FY14 ADDED EASEMENT FOR VEHICLE ACCESS TO 50-33. NEW LOT=FY03 SUBDIV.	LAND	863,500	750,800			
Inf1	NO ADJ		BUILDING	879,100	748,200			
Inf2	NO ADJ		DETACHED	0	0			
			OTHER	0	0			
			TOTAL	1,742,600	1,499,000			

D
E
T
A
C
H
E
D

TY	QUAL	COND	DIM/NOTE	YB	UNITS	ADJ PRICE	RCNLD

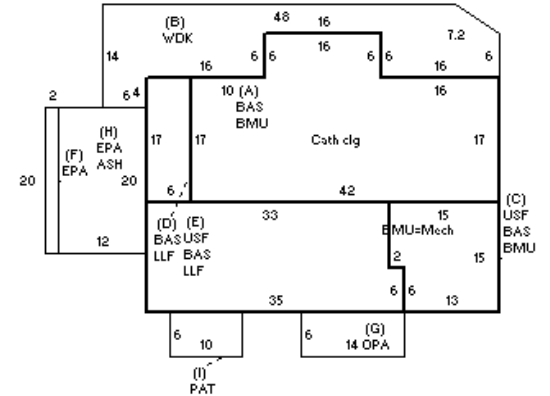

BLDG COMMENTS
Upstairs=electric heat.

B
U
I
L
D
I
N
G

BUILDING	CD	ADJ	DESC	MEASURE	11/17/2021	LG
MODEL	1		RESIDENTIAL	LIST	12/7/2021	LG
STYLE	4	1.07	CAPE [66%]	REVIEW	4/5/2021	MR
QUALITY	A	1.06	AVERAGE [83%]			
FRAME	1	1.00	WOOD FRAME [100%]			

YEAR BLT	2001	SIZE ADJ	0.985	ELEMENT	CD	DESCRIPTION	ADJ	S	BAT	T	DESCRIPTION	UNITS	YB	ADJ PRICE	RCN
NET AREA	2,961	DETAIL ADJ	1.005	FOUNDATION	4	BSMT WALL	1.00	+	BMU	N	BSMT UNFINISHED	1,023		74.35	76,058
\$NLA(RCN)	\$337	OVERALL	1.032	EXT. COVER	1	WOOD SHINGLES	1.00	A	BAS	L	BAS AREA	810	2001	316.07	256,017
				ROOF SHAPE	1	GABLE	1.00	B	WDK	N	ATT WOOD DECK	456		51.81	23,623
				ROOF COVER	1	ASPHALT SHINGLE	1.00	C	BAS	L	BAS AREA	213	2001	316.07	67,323
				FLOOR COVER	1	HARDWOOD	1.00	C	USF	L	UP-STRY FIN	213	2001	255.02	54,318
				INT. FINISH	2	DRYWALL	1.00	D	LLF	L	LOWER LEVEL FIN	102	2001	220.10	22,450
				HEATING/COOLING	2	HOT WATER	1.02	D	BAS	L	BAS AREA	102	2001	316.07	32,239
				FUEL SOURCE	2	GAS	1.00	E	LLF	L	LOWER LEVEL FIN	507	2001	220.09	111,588
								E	BAS	L	BAS AREA	507	2001	316.07	160,248
								E	USF	L	UP-STRY FIN	507	2021	255.02	129,293
								+	EPA	N	ENCL PORCH	280		134.50	37,661
								G	OPA	N	OPEN PORCH	84		96.65	8,119
								H	ASH	N	ATT SHED	240		45.15	10,836
								I	PAT	N	PATIO	60		24.51	1,471
								ODS	O	O	OUT DOOR SHOWER	1		0.00	

TOTAL RCN	998,944
CONDITION ELEM	CD
EFF.YR/AGE	2010 / 12
COND	12 12 %
FUNC	0
ECON	0
DEPR	12 % GD 88
RCNLD	\$879,100