

Key: 5909

Town of TRURO - Fiscal Year 2024

9/27/2023 7:11 pm SEQ #: 4.014

LEG
AL
LAND

CURRENT OWNER		PARCEL ID		LOCATION	
IRWIN-GIRARD SUSAN & CAROL PO BOX 2006 TRURO, MA 02666		40-159-0		10 FAIR WINDS PASSAGE	
TRANSFER HISTORY		DOS	T	SALE PRICE	BK-PG (Cert)
IRWIN-GIRARD SUSAN & CARO		03/03/2015	QS	352,000	28714-300
ATLANTIC HIGHLANDS LLC		04/30/2004	G	1,300,558	18533-79+
KING ATKINS H JR EST OF E		04/30/2004	99		6076-20+

CLASS	CLASS%	DESCRIPTION		BN ID	BN	CARD	
1010	100	SINGLE FAMILY			1	1 of 1	
PMT NO	PMT DT	TY	DESC	AMOUNT	INSP	BY	1st %
21-049	02/01/2021	3	REPAIR/REMOD	50,000	08/31/2021	LG	100 100
FY2021		35	RES EXEMPT		09/09/2020		0 0
18-389X	11/01/2018	6	SHED	8,358	03/14/2019	LG	100 100
18-062	02/22/2018	1	SINGLE FAM R	725,000	01/04/2019	LG	100 100
	04/30/2004	50	SPLIT SUB				100 100

LAND

CD	T	AC/SF/UN	Nbhd	Inf1	Inf2	ADJ BASE	SAF	Inf3	Lpi	VC	CREDIT AMT	ADJ VALUE
100	A	0.775	12	1.00	1	1.00	1	1.00	R08	1.60		446,520
300	A	0.155	12	1.00	1	1.00	1	1.00	R08	1.60		6,820

DETACHED

TOTAL	40,511 SF	ZONING	RES	FRNT	0	ASSESSED	CURRENT	PREVIOUS
Nbhd	EAST TRURO	NOTE NEW PCL FY06 PER 2004 SUBDIV.				LAND	453,300	394,200
Inf1	NO ADJ		BUILDING	1,381,800	1,140,700			
Inf2	NO ADJ		DETACHED	3,900	3,700			
			OTHER	0	0			
						TOTAL	1,839,000	1,538,600

TY	QUAL	COND	DIM/NOTE	YB	UNITS	ADJ PRICE	RCNLD
SHF	G	1.18 E	1.00 12*16	2019	192	18.34	3,500
PTD	G	1.18 E	1.00 12*12	2021	144	2.71	400

PHOTO 08/31/2021



BLDG COMMENTS

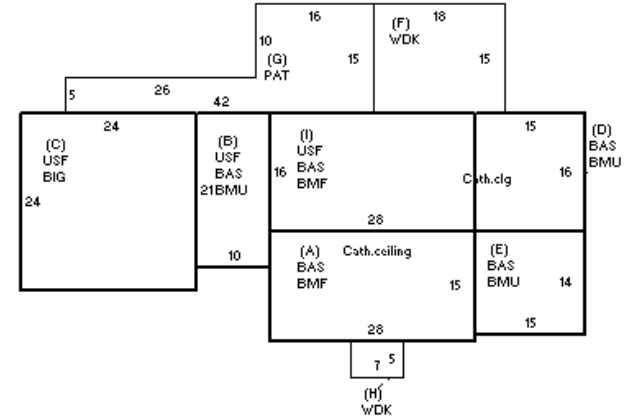

BUILDING

BUILDING	CD	ADJ	DESC	MEASURE	1/4/2019	LG
MODEL	1		RESIDENTIAL	LIST	1/4/2019	LG
STYLE	4	1.10	CAPE [100%]	REVIEW		
QUALITY	G	1.35	GOOD [100%]			
FRAME	1	1.00	WOOD FRAME [100%]			

YEAR BLT	2018	SIZE ADJ	0.985	ELEMENT	CD	DESCRIPTION	ADJ	S	BAT	T	DESCRIPTION	UNITS	YB	ADJ PRICE	RCN	TOTAL RCN	1,424,536
NET AREA	2,762	DETAIL ADJ	1.010	FOUNDATION	3	CONTIN WALL	1.00	+	BMF	N	BSMT FINISH	868		184.45	160,103		
\$NLA(RCN)	\$516	OVERALL	1.100	EXT. COVER	4	VINYL	1.00	+	BAS	L	BAS AREA	660	2018	435.60	287,496		
				ROOF SHAPE	1	GABLE	1.00	+	BMU	N	BSMT UNFINISHED	660		111.37	73,503		
				ROOF COVER	1	ASPHALT SHINGLE	1.00	+	BAS	L	BAS AREA	868	2018	435.60	378,100		
				FLOOR COVER	1	HARDWOOD	1.00	+	USF	L	UP-STRY FIN	1,234	2018	333.82	411,933		
				INT. FINISH	2	DRYWALL	1.00	C	BIG	N	BUILT-IN GARAGE	576		108.25	62,355		
				HEATING/COOLING	1	FORCED AIR	1.00	+	WDK	N	ATT WOOD DECK	305		74.72	22,791		
				FUEL SOURCE	2	GAS	1.00	G	PAT	N	PATIO	370		21.76	8,051		
								GFP	O	GAS FIREPLACE	1			13,205.50	13,206		
								ODS	O	OUT DOOR SHOWER	1			0.00			

CONDITION ELEM	CD
EFF.YR/AGE	2019 / 3
COND	03 03%
FUNC	0
ECON	0
DEPR	3 % GD 97
RCNLD	\$1,381,800