

Key: 618

Town of TRURO - Fiscal Year 2024

9/27/2023 7:11 pm SEQ #: 538

LEGAL

CURRENT OWNER		PARCEL ID		LOCATION	
REINHARDT CHERYL S 535 CASWELL RD CHAPEL HILL, NC 27514		24-30-0		5 WHALE WATCH DR	
TRANSFER HISTORY		DOS	T	SALE PRICE	BK-PG (Cert)
REINHARDT CHERYL S		11/16/2012	A		(198719)
REINHARDT DIANA		11/16/2012	A		(198718)
REINHARDT DIANA REV TRUST		01/09/2012	99		(196060)

CLASS	CLASS%	DESCRIPTION		BN ID	BN	CARD	
1010	100	SINGLE FAMILY			1	1 of 1	
PMT NO	PMT DT	TY	DESC	AMOUNT	INSP	BY	1st %
99-124	07/01/1999	1	SINGLE FAM R	200,000	01/01/2001		100 100

LAND

CD	T	AC/SF/UN	Nbhd	Inf1	Inf2	ADJ BASE	SAF	Inf3	Lpi	VC	CREDIT AMT	ADJ VALUE
100	A	0.775 11 1.00	1	1.00	1	1.00	630,175	1.00	1	1.00	V7	1.75
300	A	0.215 11 1.00	1	1.00	1	1.00	48,125	1.00	1	1.00	V7	1.75

DETACHED

TOTAL	43,124 SF	ZONING	RES	FRNT	0	ASSESSED	CURRENT	PREVIOUS
Nbhd	NORTH TRURO	NOTE				LAND	498,700	433,600
Inf1	NO ADJ		BUILDING	1,306,900	1,081,900			
Inf2	NO ADJ		DETACHED	0	0			
			OTHER	0	0			
						TOTAL	1,805,600	1,515,500

TY	QUAL	COND	DIM/NOTE	YB	UNITS	ADJ PRICE	RCNLD

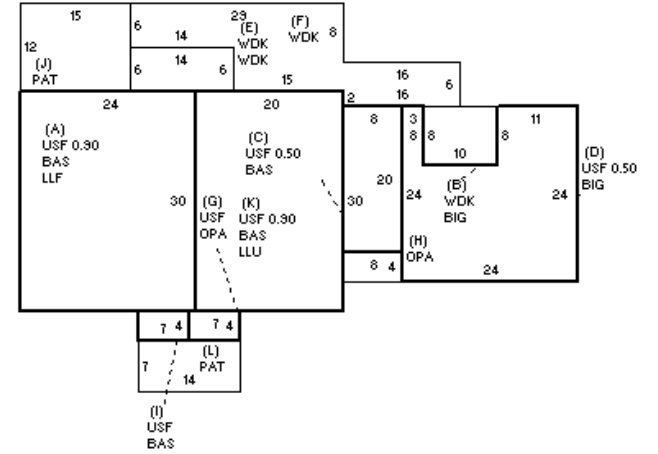

BUILDING

BUILDING	CD	ADJ	DESC	MEASURE	2/5/2020	LG
MODEL	1		RESIDENTIAL	LIST	10/9/2012	BE
STYLE	4	1.10	CAPE [100%]	REVIEW	4/7/2021	MR
QUALITY	G	1.35	GOOD [100%]			
FRAME	1	1.00	WOOD FRAME [100%]			

BLDG COMMENTS

INDING

YEAR BLT	1999	SIZE ADJ	0.975	ELEMENT	CD	DESCRIPTION	ADJ	S	BAT	T	DESCRIPTION	UNITS	YB	ADJ PRICE	RCN	TOTAL RCN	1,697,210	
NET AREA	3,800	DETAIL ADJ	1.000	FOUNDATION	4	BSMT WALL	1.00	A	LLF	L	LOWER LEVEL FIN	720	1999	301.12	216,809	CONDITION ELEM	CD	
\$NLA(RCN)	\$447	OVERALL	1.120	EXT. COVER	1	WOOD SHINGLES	1.00	+	USF	L	UP-STRY FIN	1,572	1999	331.10	520,486			
				ROOF SHAPE	1	GABLE	1.00	+	BIG	N	BUILT-IN GARAGE	576		109.10	62,844			
				ROOF COVER	1	ASPHALT SHINGLE	1.00	+	BAS	L	BAS AREA	1,508	1999	439.02	662,037			
				FLOOR COVER	1	HARDWOOD	1.00	+	WDK	N	ATT WOOD DECK	608		66.45	40,402			
				INT. FINISH	2	DRYWALL	1.00	+	OPA	N	OPEN PORCH	60		149.48	8,969			
				HEATING/COOLING	2	HOT WATER	1.02	+	PAT	N	PATIO	278		23.22	6,456			
				FUEL SOURCE	1	OIL	1.00	K	LLU	N	LOWER LEVEL UNF	600		229.43	137,656			
								F22	O	FPL 2S ZOP	1		31,052.50	31,053				
								ODS	O	OUT DOOR SHOWER	1		0.00					
																	EFF.YR/AGE	1999 / 23
																	COND	23 23 %
																	FUNC	0
																	ECON	0
																	DEPR	23 % GD 77
																	RCNLD	\$1,306,900