

Key: 6559

Town of TRURO - Fiscal Year 2024

9/27/2023 7:11 pm SEQ #: 4.241

LEGALS

LAND

CURRENT OWNER				PARCEL ID				LOCATION				
TRACY MAYNARD SILVER TRUST SILVER TRACY M TRUSTEE 112 EAST 19TH ST APT 9F NEW YORK, NY 10003				45-146-0				2 OBBO DR				
TRANSFER HISTORY				DOS	T	SALE PRICE		BK-PG (Cert)				
TRACY MAYNARD SILVER TRUS				03/24/2017	F	10 (207802)						
SILVER TRACY				10/30/2015	P	735,000 (207802)						
M B O-J G O LLC				12/18/2008	J	3,500,000 (187580+)						
CD	T	AC/SF/UN	Nbhd	Infl1	Infl2	ADJ BASE	SAF	Infl3	Lpi	VC	CREDIT AMT	ADJ VALUE
100	A	0.775 11 1.00	T2	0.50 1 1.00	1,260,350	1.00 1	1.00	WF2	7.00			976,770
300	A	0.492 11 1.00	CR	0.25 1 1.00	48,125	1.00 1	1.00	WF2	7.00			23,680

CLASS	CLASS%	DESCRIPTION			BN ID	BN	CARD	
1010	100	SINGLE FAMILY				1	1 of 1	
PMT NO	PMT DT	TY	DESC	AMOUNT	INSP	BY	1st	%
18-290	09/06/2018	80	SOLAR TAXABL	27,000	11/09/2018	LG	100	100
15-292	11/20/2015	1	SINGLE FAM R	1,300,000	12/13/2016	LG	100	100
09-SM06	01/01/2010	50	SPLIT SUB				100	100

TOTAL	1.267 Acres	ZONING	RES	FRNT	0	ASSESSED	CURRENT	PREVIOUS
Nbhd	NORTH TRURO	N	FY11 NEW PCL PER SUBDIV FROM RESI PCL			LAND	1,000,500	869,900
Infl1	TOPOGRAPHY	O	45-1=UNREG+P/O COMM PCL 42-191=REG. FY12 ST#			BUILDING	2,359,300	2,022,700
Infl2	NO ADJ	T	CHG PER PLAN 638-22 FOR CR (CHG'D ACCESS			DETACHED	0	0
		E	POINT). LOT4 INFL1=CONSERVATION/DEED			OTHER	0	0
			RESTRICTION			TOTAL	3,359,800	2,892,600

DETACHED

TY	QUAL	COND	DIM/NOTE	YB	UNITS	ADJ PRICE	RCNLD



BLDG COMMENTS

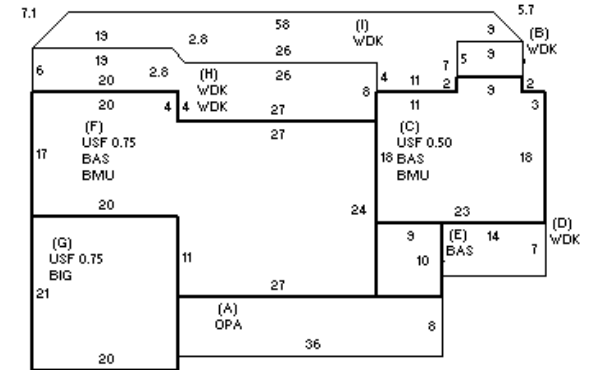

BUILDING

BUILDING	CD	ADJ	DESC	MEASURE	12/13/2016	LG
MODEL	1		RESIDENTIAL	LIST	6/15/2017	LG
STYLE	16	1.30	NEW STYLE [100%]	REVIEW	6/15/2017	CF
QUALITY	E	2.00	EXCELLENT [100%]			
FRAME	1	1.00	WOOD FRAME [100%]			

YEAR BLT	2015	SIZE ADJ	0.985	ELEMENT	CD	DESCRIPTION	ADJ	S	BAT	T	DESCRIPTION	UNITS	YB	ADJ PRICE	RCN	TOTAL RCN	2,536,882
NET AREA	2,782	DETAIL ADJ	1.000	FOUNDATION	3	CONTIN WALL	1.00	A	OPA	N	OPEN PORCH	288		186.70	53,770	CONDITION ELEM	CD
\$NLA(RCN)	\$912	OVERALL	1.350	EXT. COVER	1	WOOD SHINGLES	1.00	+	WDK	N	ATT WOOD DECK	1,241		119.88	148,767		
CAPACITY				ROOF SHAPE	1	GABLE	1.00	+	BMU	N	BSMT UNFINISHED	1,420		171.04	242,879		
STORIES(FAR)	1.75	1.00	ROOF COVER	1	ASPHALT SHINGLE	1.00	+	USF	L	UP-STRY FIN	1,272	2015	606.95	772,034			
ROOMS	7	1.00	FLOOR COVER	1	HARDWOOD	1.00	+	BAS	L	BAS AREA	1,510	2015	792.00	1,195,919			
BEDROOMS	4	1.00	INT. FINISH	2	DRYWALL	1.00	G	BIG	N	BUILT-IN GARAGE	420		210.25	88,303			
BATHROOMS	4.5	1.00	HEATING/COOLING	11	HOT WAT.-CL AIR	1.05	GFP	O	GAS FIREPLACE	1			24,010.00	24,010			
FIXTURES	16	\$11,200	FUEL SOURCE	2	GAS	1.00											
UNITS	1	1.00															
EFF.YR/AGE 2015 / 7																	
COND 07 07 %																	
FUNC 0																	
ECON 0																	
DEPR 7 % GD 93																	
RCNLD \$2,359,300																	