

Key: 748

Town of TRURO - Fiscal Year 2024

9/27/2023 7:11 pm SEQ #: 665

LEGAL

LAND

DETACHED

BUILDING

CURRENT OWNER				PARCEL ID				LOCATION			
STAFF ARTHUR A & CATHERINE L PO BOX 588 NO TRURO, MA 02652-0588				35-5-0				24 WINDIGO LN			
TRANSFER HISTORY				DOS	T	SALE PRICE	BK-PG (Cert)				
STAFF ARTHUR A & CATHERIN				05/08/1985	QS	79,500	(101436)				

CLASS	CLASS%	DESCRIPTION			BN ID	BN	CARD	
1010	100	SINGLE FAMILY				1	1 of 1	
PMT NO	PMT DT	TY	DESC	AMOUNT	INSP	BY	1st	%
FY2018		35	RES EXEMPT		10/01/2017			0
00-094	06/01/2000	10	ALL OTHERS	450	01/01/2001		100	100
89-103	07/14/1989	2	ADDITION	35,000	12/31/1989		100	100

CD	T	AC/SF/UN	Nbhd	Inf1	Inf2	ADJ BASE	SAF	Inf3	Lpi	VC	CREDIT AMT	ADJ VALUE	
100	A	0.520	11	1.00	1	1.00	1.00	630,175	1.32	1	1.00	V5 1.75	431,900

TOTAL	22,651 SF	ZONING	RES	FRNT	0	ASSESSED	CURRENT	PREVIOUS
Nbhd	NORTH TRURO	NOTE			LAND	431,900	375,500	
Inf1	NO ADJ		BUILDING	433,000	367,400			
Inf2	NO ADJ		DETACHED	4,300	4,200			
			OTHER	0	0			
TOTAL						869,200	747,100	

TY	QUAL	COND	DIM/NOTE	YB	UNITS	ADJ PRICE	RCNLD
WDK	A	1.00	A 0.75	14*20	280	11.00	2,300
HTB	A	1.00	A 0.75		1	2,730.40	2,000

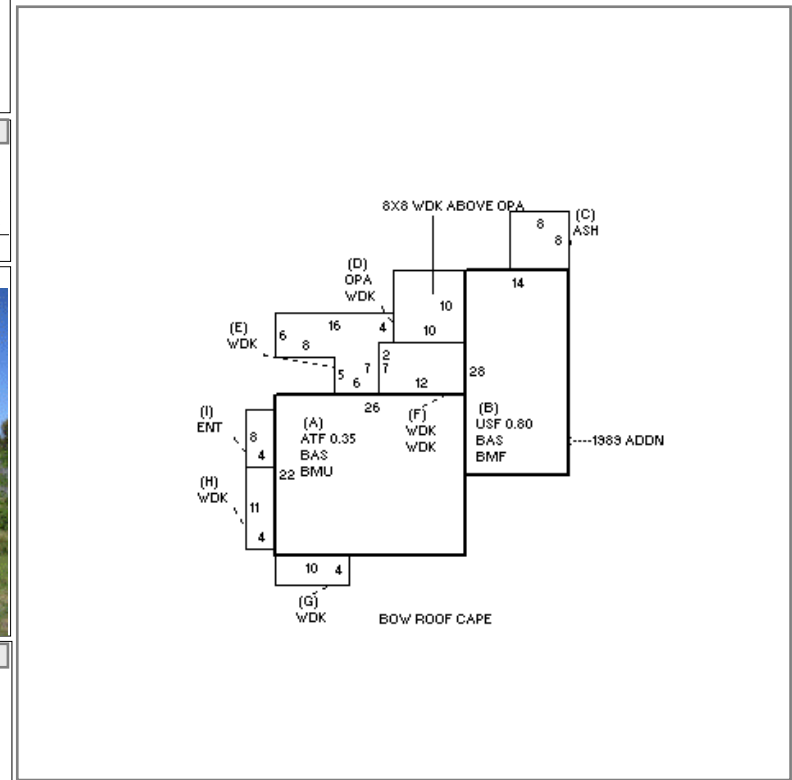

BUILDING	CD	ADJ	DESC	MEASURE	6/21/2018	LG
MODEL	1		RESIDENTIAL	LIST	6/21/2018	LG
STYLE	4	1.10	CAPE [100%]	REVIEW	11/15/2010	MR
QUALITY	A	1.00	AVERAGE [100%]			
FRAME	1	1.00	WOOD FRAME [100%]			

BLDG COMMENTS
6/21/18 List: 3rd BR access. rt wing stairs. Rt wing BMF.

YEAR BLT	1970	SIZE ADJ	1.030	ELEMENT	CD	DESCRIPTION	ADJ	S	BAT	T	DESCRIPTION	UNITS	YB	ADJ PRICE	RCN	
NET AREA	1,278	DETAIL ADJ	1.000	FOUNDATION	4	BSMT WALL	1.00	A	BMU	N	BSMT UNFINISHED	572		94.24	53,903	
\$NLA(RCN)	\$498	OVERALL	1.120	EXT. COVER	1	WOOD SHINGLES	1.00	+	BAS	L	BAS AREA	964	1970	350.41	337,798	
CAPACITY						ROOF SHAPE	1.00	A	ATF	N	FINISHED ATTIC	200		181.23	36,246	
STORIES(FAR)	1.8		1.00	ROOF COVER	1	ASPALT SHINGLE	1.00	B	BMF	N	BSMT FINISH	392		164.82	64,609	
ROOMS	8		1.00	FLOOR COVER	2	SOFTWOOD	1.00	F	USF	L	UP-STRY FIN	314	1970	277.20	87,041	
BEDROOMS	3		1.00	INT. FINISH	2	DRYWALL	1.00	C	ASH	N	ATT SHED	64		48.34	3,094	
BATHROOMS	2		1.00	HEATING/COOLING	2	HOT WATER	1.02	+	WDK	N	ATT WOOD DECK	474		55.47	26,291	
FIXTURES	6	\$4,200		FUEL SOURCE	1	OIL	1.00	D	OPA	N	OPEN PORCH	100		103.48	10,348	
UNITS	0	1.00						I	ENT	N	ENCL ENTRY	32		232.02	7,425	
TOTAL RCN																636,722
CONDITION ELEM																CD
EFF.YR/AGE																1979 / 43
COND																32 32 %
FUNC																0
ECON																0
DEPR																32 % GD 68
RCNLD																\$433,000