

Key: 826

Town of TRURO - Fiscal Year 2024

9/27/2023 7:11 pm SEQ #: 765

LEG
AL
LAND

CURRENT OWNER		PARCEL ID		LOCATION								
GAGNE MICHAEL J & KATHY S 27 MARION ST EAST GREENWICH, RI 01757		35-75-0		45 TWINE FIELD RD								
TRANSFER HISTORY		DOS	T	SALE PRICE	BK-PG (Cert)							
GAGNE MICHAEL J & KATHY S		09/04/2018	QS	810,000	31507-161							
CAVANAUGH JEAN R		03/24/2008	99		2478-162+							
CAVANAUGH PETER P & JEAN		03/10/1977	99		2478-162							
CD	T	AC/SF/UN	Nbhd	Inf1	Inf2	ADJ BASE	SAF	Inf3	Lpi	VC	CREDIT AMT	ADJ VALUE
100	A	0.775 11 1.00	1	1.00	1	900,250	1.00	1	1.00	V9	2.50	697,690
300	A	0.148 11 1.00	1	1.00	1	68,750	1.00	1	1.00	V9	2.50	10,180

CLASS	CLASS%	DESCRIPTION		BN ID	BN	CARD	
1010	100	SINGLE FAMILY			1	1 of 1	
PMT NO	PMT DT	TY	DESC	AMOUNT	INSP	BY	1st %
22-463X	11/23/2022	4	REHAB	34,350	01/31/2023	LG	100 100
19-010	01/08/2019	3	REPAIR/REMOD	120,362	10/01/2021	lg	100 100
06-063	03/29/2006	90	BP NVC	4,200	05/04/2007	JH	100 100

DET
ACHED

TOTAL	40,218 SF	ZONING	RES	FRNT	0	ASSESSED	CURRENT	PREVIOUS
Nbhd	NORTH TRURO	N O T E	9/4/18 SF chng per Bk 31507 Pg 161.			LAND	707,900	615,500
Inf1	NO ADJ		BUILDING	575,800	461,000			
Inf2	NO ADJ		DETACHED	3,100	0			
			OTHER	0	0			
			TOTAL	1,286,800	1,076,500			

TY	QUAL	COND	DIM/NOTE	YB	UNITS	ADJ PRICE	RCNLD
HTB	CG	1.25 G	0.90	2022	1	3,413.00	3,100

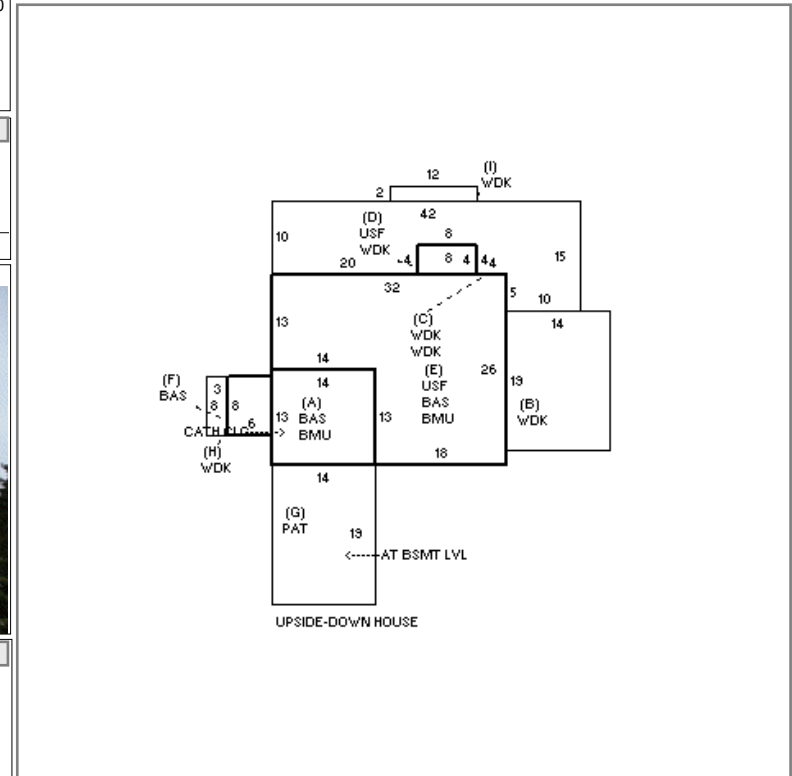

B
U
I
L
D
I
N
G

BUILDING	CD	ADJ	DESC	MEASURE	4/12/2018	LG
MODEL	1		RESIDENTIAL	LIST	9/20/2019	LG
STYLE	5	1.05	COLONIAL [100%]	REVIEW	11/15/2010	MR
QUALITY	+	1.15	GOOD-AVE+ [100%]			
FRAME	1	1.00	WOOD FRAME [100%]			

BLDG COMMENTS

YEAR BLT	1980	SIZE ADJ	1.020	ELEMENT	CD	DESCRIPTION	ADJ	S	BAT	T	DESCRIPTION	UNITS	YB	ADJ PRICE	RCN	TOTAL RCN	710,851
NET AREA	1,562	DETAIL ADJ	1.000	FOUNDATION	4	BSMT WALL	1.00	+	BMU	N	BSMT UNFINISHED	832		90.49	75,290		
\$NLA(RCN)	\$455	OVERALL	1.070	EXT. COVER	1	WOOD SHINGLES	1.00	A	BAS	L	BAS AREA	182	1980	381.25	69,388		
				ROOF SHAPE	6	SALTBOX	1.00	+	W/DK	N	ATT WOOD DECK	1,222		56.57	69,134		
				ROOF COVER	1	ASPHALT SHINGLE	1.00	+	USF	L	UP-STRY FIN	682	1980	297.05	202,586		
				FLOOR COVER	3	W/W CARPET	1.00	E	BAS	L	BAS AREA	650	1980	381.25	247,810		
				INT. FINISH	2	DRYWALL	1.00	F	BAS	L	BAS AREA	48	2019	381.24	18,300		
				HEATING/COOLING	2	HOT WATER	1.02	G	PAT	N	PATIO	266		19.77	5,259		
				FUEL SOURCE	1	OIL	1.00		F21	O	FPL 2S 1OP	1		18,884.40	18,884		
																CONDITION ELEM	CD
																EFF.YR/AGE	2003 / 19
																COND	19 19 %
																FUNC	0
																ECON	0
																DEPR	19 % GD 81
																RCNLD	\$575,800