

Key: 987

Town of TRURO - Fiscal Year 2024

9/27/2023 7:11 pm SEQ #: 940

LEGAL

LAND

DETACHED

BUILDING

CURRENT OWNER				PARCEL ID				LOCATION			
ALEXANDER IRVIN A III & MCGOWAN TYRONE K PO BOX 595 NO TRURO, MA 02652				36-98-0				5 POND VILLAGE HGTS RD			
TRANSFER HISTORY				DOS	T	SALE PRICE	BK-PG (Cert)				
ALEXANDER IRVIN A III & SHEA CAROL M REVOCABLE TR				08/31/2012	QS	468,500	26640-48				
SHEA CAROL M REVOCABLE TR				02/09/2010	J		19793-22+				
SHEA CAROL M REVOCABLE TR				02/09/2010	J		19793-22+				

CLASS	CLASS%	DESCRIPTION			BN ID	BN	CARD	
1010	100	SINGLE FAMILY				1	1 of 1	
PMT NO	PMT DT	TY	DESC	AMOUNT	INSP	BY	1st	%
17-100X	04/12/2017	6	SHED	15,500	02/12/2018	LG	100	100
16-122	06/08/2016	80	SOLAR TAXABL	6,400	02/08/2017	LG	100	100
		30	CHECK DATA		03/09/2012	FC	100	100
11-233	11/09/2011	90	BP NVC	1,645	03/09/2012	FC	100	100
04-098	06/21/2004	9	DECK	7,430	05/13/2005	WL	100	100

CD	T	AC/SF/UN	Nbhd	Inf1	Inf2	ADJ BASE	SAF	Inf3	Lpi	VC	CREDIT AMT	ADJ VALUE
100	A	0.570	11	1.00	1	1.00	1	1.00	V4	1.45		368,100

TOTAL	24,829 SF	ZONING	RES	FRNT	0	ASSESSED	CURRENT	PREVIOUS
Nbhd	NORTH TRURO	NOTE				LAND	368,100	320,100
Inf1	NO ADJ		BUILDING	511,100	415,100			
Inf2	NO ADJ		DETACHED	13,700	13,100			
			OTHER	0	0			
						TOTAL	892,900	748,300

TY	QUAL	COND	DIM/NOTE	YB	UNITS	ADJ PRICE	RCNLD
ST1	A	1.00	A 0.75 12*16	2017	192	95.40	13,700

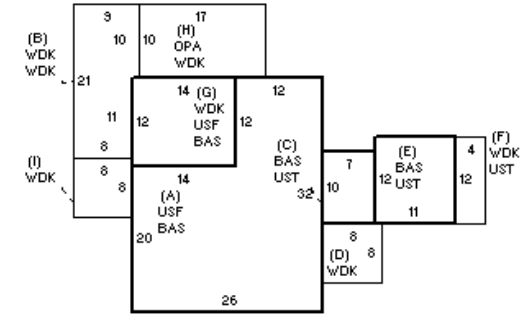

BUILDING	CD	ADJ	DESC	MEASURE	3/18/2022	LG
MODEL	1		RESIDENTIAL	LIST	2/17/2017	LG
STYLE	5	1.05	COLONIAL [100%]	REVIEW	2/15/2013	BE
QUALITY	+	1.15	GOOD-AVE+ [100%]			
FRAME	1	1.00	WOOD FRAME [100%]			

BLDG COMMENTS

YEAR BLT	1973	SIZE ADJ	1.010	ELEMENT	CD	DESCRIPTION	ADJ	S	BAT	T	DESCRIPTION	UNITS	YB	ADJ PRICE	RCN	TOTAL RCN	740,680																				
NET AREA	1,866	DETAIL ADJ	1.000	FOUNDATION	4	BSMT WALL	1.00	+	BAS	L	BAS AREA	1,034	1973	377.51	390,345																						
\$NLA(RCN)	\$397	OVERALL	1.070	EXT. COVER	1	WOOD SHINGLES	1.00	+	USF	L	UP-STRY FIN	832	1973	291.13	242,223																						
				ROOF SHAPE	1	GABLE	1.00	+	WDK	N	ATT WOOD DECK	870		56.02	48,737																						
				ROOF COVER	1	ASPHALT SHINGLE	1.00	+	UST	N	UTILITY STORAGE	250		134.72	33,680																						
				FLOOR COVER	5	VINYL	1.00	H	OPA	N	OPEN PORCH	170		92.09	15,656																						
				INT. FINISH	2	DRYWALL	1.00	MST	O	MASONRY STACK	1			3,739.60	3,740																						
				HEATING/COOLING	2	HOT WATER	1.02	ODS	O	OUT DOOR SHOWER	1			0.00																							
				FUEL SOURCE	2	GAS	1.00																														
				<table border="1"> <thead> <tr> <th>COND</th> <th>31</th> <th>%</th> <th>31</th> <th>%</th> </tr> </thead> <tbody> <tr> <td>FUNC</td> <td>0</td> <td></td> <td>0</td> <td></td> </tr> <tr> <td>ECON</td> <td>0</td> <td></td> <td>0</td> <td></td> </tr> <tr> <td>DEPR</td> <td>31</td> <td>%</td> <td>GD</td> <td>69</td> </tr> </tbody> </table>														COND	31	%	31	%	FUNC	0		0		ECON	0		0		DEPR	31	%	GD	69
COND	31	%	31	%																																	
FUNC	0		0																																		
ECON	0		0																																		
DEPR	31	%	GD	69																																	
				<table border="1"> <thead> <tr> <th>EFF.YR/AGE</th> <td colspan="3">1984 / 38</td> </tr> </thead> <tbody> <tr> <td>RCNLD</td> <td colspan="3">\$511,100</td> </tr> </tbody> </table>														EFF.YR/AGE	1984 / 38			RCNLD	\$511,100														
EFF.YR/AGE	1984 / 38																																				
RCNLD	\$511,100																																				